

# K150

## FEATURES

- HEAVY DUTY CONDITIONS
- HIGH FLOW RATE
- BURSTING PRESSURE 28 BAR
- EASY READING
- 4 FLOW DIRECTIONS

K150 is expressly engineered to meet the market requirements of a meter suitable for flow rates superior than 120 l/min and that can be used both for fluids such as diesel and biodiesel, as well as in potentially explosives atmosphere; with gasoline for example. K150 is easy to calibrate and ready to use; its aluminium cover and sturdy body make this meter suitable for a wide arrange of application while guaranteeing the same precision and quality that have always featured PIUSI equipment. The mechanical display allows to read quickly the quantity dispensed. It can be installed everywhere thanks to the (optional) 1,5" flange kit.

### PERFORMANCE

UP TO

**150**

L/MIN

FLOW RATE

**3,5 BAR**

MAX

OPERATING PRESSURE

**± 1%**

ACCURACY

**0,3%**

REPEATABILITY

**K150**

### PACKAGING

CODE	WEIGHT		PACKAGING			BOXES/EUROPALLET	
	KG	LBS	MM	INCH	PCS/BOX	✕	
FO0554A00	2,38	5,25	185X185X170	7,28X7,28X6,69	1	192	240
FO0554B00	2,38	5,25	185X185X170	7,28X7,28X6,69	1	192	240
FO0554C00	2,38	5,25	185X185X170	7,28X7,28X6,69	1	192	240
FO0554D00	2,38	5,25	185X185X170	7,28X7,28X6,69	1	192	240



AIR



ANTIFREEZE



AdBlue®



BIODIESEL



DIESEL



FOOD



GASOLINE



GREASE



KEROSENE



OIL



WATER



WINDSCREEN

## CHART

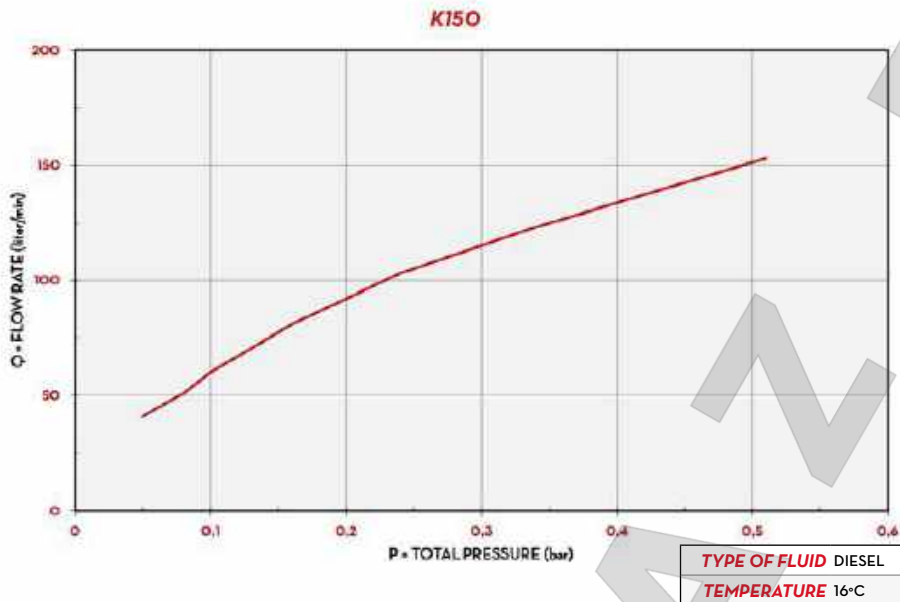

## IN THE BOX

- K150 METER
- INSTRUCTION MANUAL

## DETAILS



NUTATING DISK



4 FLOW DIRECTIONS



METALLIC COVER

## DIMENSIONS

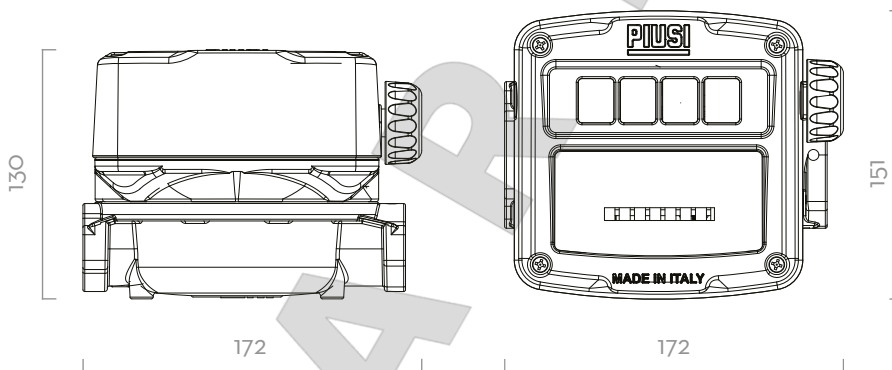

Dimensions expressed in millimeters

## MATERIALS

- BODY AND COVER: ALUMINIUM
- NUTATING DISK CHAMBER: TECHNOPOLYMER

## TECHNICAL DATA

CODE	DESCRIPTION	FLUIDS TYPE	FLOW RATE		FLOW DIRECTIONS	PRESSURE		INLET/OUTLET
			L/MIN	GPM		BAR	PSI	
FO0554A00	K150 METER LITERS - 1" BSP VER.A	D	25-150	6,6-40	◀	3,5	50	1" BSP
FO0554B00	K150 METER LITERS - 1" BSP VER.B	D	25-150	6,6-40	▲	3,5	50	1" BSP
FO0554C00	K150 METER LITERS - 1" BSP VER.C	D	25-150	6,6-40	▼	3,5	50	1" BSP
FO0554D00	K150 METER LITERS - 1" BSP VER.D	D	25-150	6,6-40	▶	3,5	50	1" BSP

THE PIUSI K150 IS A MECHANICAL METER EXPRESSLY ENGINEERED FOR HEAVY DUTY AND HIGH FLOW RATE APPLICATIONS. IT IS EASY TO CALIBRATE AND READY-TO-USE: ITS ALUMINIUM COVER AND STURDY BODY MAKE THIS METER SUITABLE FOR A WIDE ARRANGE OF APPLICATIONS WHILE GUA-

K150