

PIUSIBOX

FEATURES

- SELF PRIMING PUMP
- BUILT-IN FILTER (PRO VERSION)
- EASY TO REPACK
- IP55

The PIUSIBOX is a portable fuel dispenser integrated with a self-priming transfer pump, filter, check valve and manual nozzle. Suitable for quick and safe refuel operations in all the situations where an easy mobile refueling solution is required.

PERFORMANCE

UP TO

45 L/MIN

FLOW RATE

12/24V

VOLTAGE



POWER

30 MIN

DUTY CYCLE

PIUSIBOX

PACKAGING

CODE	WEIGHT		PACKAGING			N. BOXES / EUROPALLET	
	KG	LBS	MM	INCH	PCS/BOX		
FOO23100B	9,5	20,9	400X300X420	-	1	24	32
FOO23101B	12	26,5	400X300X420	-	1	24	32
FOO23200B	9,5	20,9	400X300X420	-	1	24	32
FOO23201B	12	26,5	400X300X420	-	1	24	32

CHART

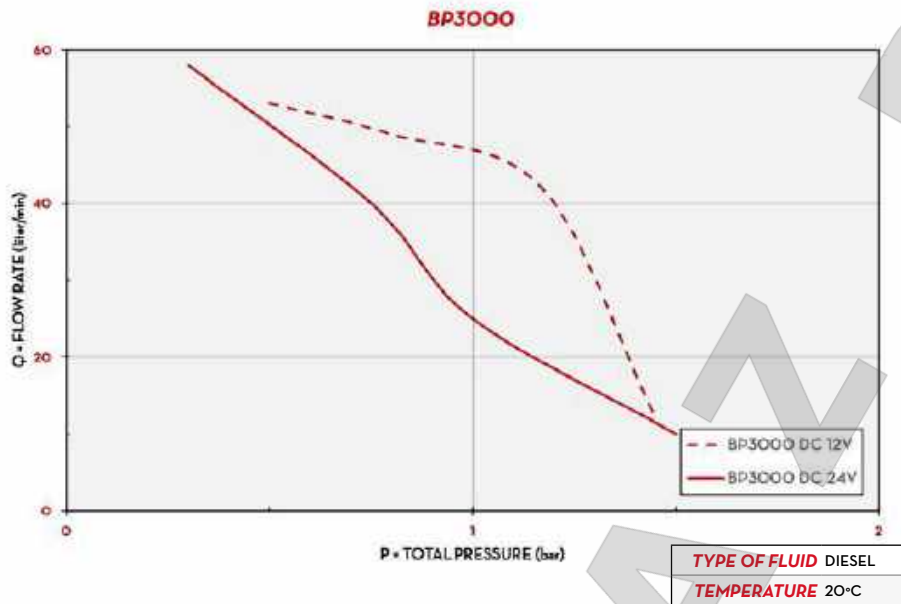

IN THE BOX

- PIUSIBOX UNIT
- SUCTION&DELIVERY HOSE
- OIL&FUEL FILTER (PRO VERSION)
- CHECK VALVE
- INSTRUCTION MANUAL

DETAILS

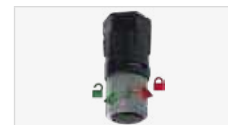

CHECK VALVE



ERGONOMIC HANDLE



ROTATING CONNECTION

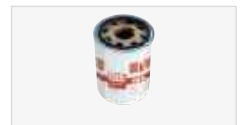

CARTRIDGE (PAG. 90)

DIMENSIONS

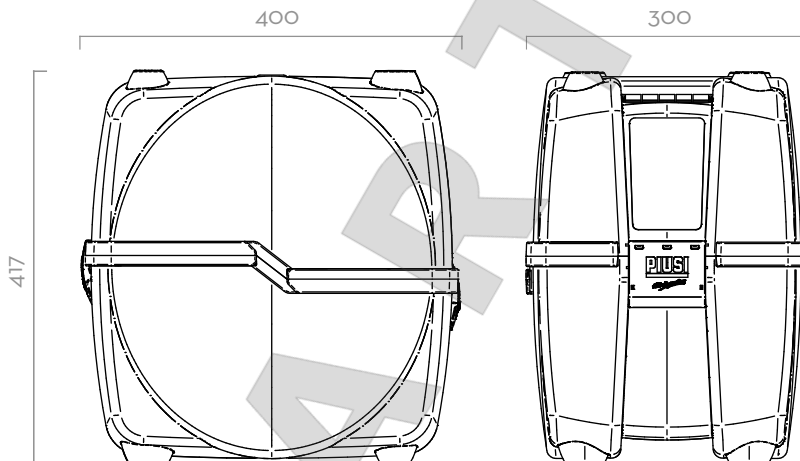

Dimensions expressed in millimeters

MATERIALS

- BODY: CAST IRON
- ROTOR: SINTERED STEEL
- VANES: ACETAL RESIN
- SEAL: NBR
- SHAFT: STEEL

TECHNICAL DATA

CODE	DESCRIPTION	FLUIDS TYPE	FLOW RATE		VOLTAGE			PUMP TYPE	DUTY CYCLE MINUTES	FILTER	CARTRIDGE	NOZZLE TYPE	DELIVERY HOSE 5/8"	SUCTION HOSE 3/4"	FOOT VALVE MOD. VANTAGE
			L/MIN	GPM	AC V/ HZ DC VOLT	POWER WATT	AMP. MAX.								
FOO23100B	PIUSIBOX 12V BASIC	D	45	11,9	12	400	33	BP 3000	30	NO	NO	MAN.	4M	2M	YES
FOO23101B	PIUSIBOX 12V PRO	D	43	11,7	12	620	26	BP 3000	30	YES	10μ	MAN.	4M	2M	YES
FOO23200B	PIUSIBOX 24V BASIC	D	45	11,9	24	400	33	BP 3000	30	NO	NO	MAN.	4M	2M	YES
FOO23201B	PIUSIBOX 24V PRO	D	43	11,7	24	620	26	BP 3000	30	YES	10μ	MAN.	4M	2M	YES