

По вопросам продаж и поддержки обращайтесь:

Алматы (7273)495-231	Казань (843)206-01-48	Новокузнецк (3843)20-46-81	Смоленск (4812)29-41-54
Архангельск (8182)63-90-72	Калининград (4012)72-03-81	Новосибирск (383)227-86-73	Сочи (862)225-72-31
Астрахань (8512)99-46-04	Калуга (4842)92-23-67	Омск (3812)21-46-40	Ставрополь (8652)20-65-13
Барнаул (3852)73-04-60	Кемерово (3842)65-04-62	Орел (4862)44-53-42	Сургут (3462)77-98-35
Белгород (4722)40-23-64	Киров (8332)68-02-04	Оренбург (3532)37-68-04	Тверь (4822)63-31-35
Брянск (4832)59-03-52	Краснодар (861)203-40-90	Пенза (8412)22-31-16	Томск (3822)98-41-53
Владивосток (423)249-28-31	Красноярск (391)204-63-61	Пермь (342)205-81-47	Тула (4872)74-02-29
Волгоград (844)278-03-48	Курск (4712)77-13-04	Ростов-на-Дону (863)308-18-15	Тюмень (3452)66-21-18
Вологда (8172)26-41-59	Липецк (4742)52-20-81	Рязань (4912)46-61-64	Ульяновск (8422)24-23-59
Воронеж (473)204-51-73	Магнитогорск (3519)55-03-13	Самара (846)206-03-16	Уфа (347)229-48-12
Екатеринбург (343)384-55-89	Москва (495)268-04-70	Санкт-Петербург (812)309-46-40	Хабаровск (4212)92-98-04
Иваново (4932)77-34-06	Мурманск (8152)59-64-93	Саратов (845)249-38-78	Челябинск (351)202-03-61
Ижевск (3412)26-03-58	Набережные Челны (8552)20-53-41	Севастополь (8692)22-31-93	Череповец (8202)49-02-64
Иркутск (395)279-98-46	Нижний Новгород (831)429-08-12	Симферополь (3652)67-13-56	Ярославль (4852)69-52-93
Россия (495)268-04-70	Киргизия (996)312-96-26-47	Казахстан (7172)727-132	



ARTAZ
ГРУППА КОМПАНИЙ





Москва, шоссе Энтузиастов 31с50
Санкт-Петербург, ул. Заусадебная 31

ООО «АРТАЗ» +7 (958) 762-88-45, <https://artaz.ru>, Почта: info@artaz.ru
Видеобзоры оборудования: <https://youtube.com/@artazru>



Ravaglioli

COMPANY WITH
QUALITY SYSTEM
CERTIFIED BY DNV GL
= ISO 9001 =

SOLLEVATORI PER VEICOLI INDUSTRIALI 
COMMERCIAL VEHICLE LIFTS 
HEBEBÜHNEN FÜR NUTZFAHRZEUGE 
ELEVATEURS POUR VEHICULES INDUSTRIELS 
ELEVADORES PARA VEHICULOS INDUSTRIALES 

RAV

825

835



60
SINCE 1958



ARTAZ
ГРУППА КОМПАНИЙ

Москва, шоссе Энтузиастов 31с50
Санкт-Петербург, ул. Заусадебная 31

ООО «АРТАЗ» +7 (958) 762-88-45, <https://artaz.ru>, Почта: info@artaz.ru
Видеобзоры оборудования: <https://youtube.com/@artazru>



Assenza dei collegamenti meccanici tra le pedane. Massima operatività nella zona di lavoro.

No cross rails or torsion bars between lifting platforms. Maximum accessibility in the working area.

Keine mechanischen Verbindungen zwischen den Fahrschienen. Rundum perfekt zugänglich.

Absence de connexions mécaniques entre les chemins de roulement. Fonctionnalité maximale dans la zone de travail.

Ausencia de conexiones mecánicas entre las plataformas. Máxima operatividad en el área de trabajo.

Sincronizzazione elettronica dei movimenti delle pedane indipendentemente dalla ripartizione del carico.

Electronic synchronisation of the platforms, independently from the load distribution.

Elektronischer Gleichlauf der Fahrschienen unabhängig von der Lastverteilung.

Synchronisation électronique des mouvements des chemins de roulement indépendante de la répartition de la charge.

Sincronización electrónica de los movimientos de las plataformas independientemente del reparto de la carga.

Dispositivo di appoggio meccanico ad inserimento automatico e disinserimento pneumatico, a garanzia della massima sicurezza in fase di stazionamento.

Mechanical locking device with automatic engagement and pneumatic release, ensuring maximum safety when lift is in standing position.

Mechanische Sicherheitsklinke garantiert eine maximale Sicherheit auch im angehobenen Zustand der Hebebühne.

Dispositif de soutien mécanique avec enclenchement automatique et dégageement pneumatique, pour garantir la sécurité totale pendant la stationnement.

Dispositivo de apoyo mecánico de funcionamiento automático y desbloqueo neumático, como garantía de la máxima seguridad en la fase de estacionamiento.

Perni di articolazione con boccole autolubrificanti non richiedenti manutenzione.

All pivot points made with self lubricating bushings for long life.

Gelenkbolzen mit selbstschmierenden Buchsen die keiner Wartung bedürfen.

Pivots d'articulation avec bagues autolubrifiantes, ne nécessitant pas d'entretien.

Pernos de articulación con casquillos autolubrificantes que no requieren mantenimiento alguno.

	Portata Capacity Tragfähigkeit Capacité Capacidad	Lunghezza pedane Long platforms Plattformlänge Longues plateformes Plataformas largas	Lunghezza totale Total length Gesamtlänge Longues totale Longitud total
	kg	mm (A)	mm (B)
RAV 825.8	25.000	8.000	10.700
RAV 825.9	25.000	9.000	11.700
RAV 825.10	25.000	10.000	12.700
RAV 835.9	35.000	9.000	11.700
RAV 835.10	35.000	10.000	12.700
RAV 835.13	35.000	13.000	15.700
RAV 825.10A	25.000	10.000	12.700
RAV 835.10A	35.000	10.000	12.700

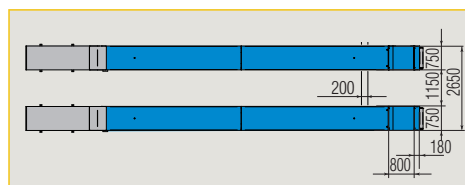
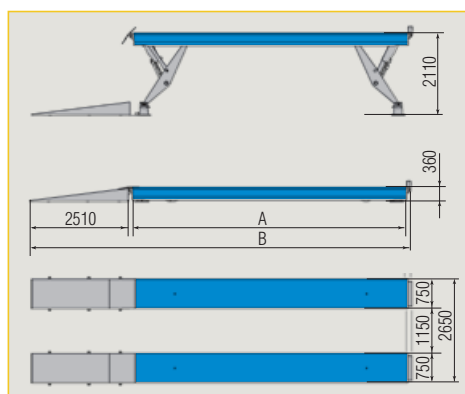

Superficie delle pedane in lamiera bugnata antiscivolo.

Platform surface in ribbed anti-slip steel plate.

Rutschfeste Fahrbahnoberfläche aus Tränenblech.

Surface des chemins de roulement en tôle ondulée anti-glisement

Superficie de las plataformas con material antideslizante

RAV 835.10A RAV 835.10AI

Pedane con sedi anteriori per piatti rotanti.

Platforms with front recesses for turning plates.

Fahrschienen vorne mit Sitzen für Drehteller.

Chemins de roulement avec logements avant pour plateaux pivotants.

Plataformas con asientos para



INCASSATI / RECESSED / UNTERFLUR VERSION / VERSIONS ENCASTREES / EMPOTRADOS

Tutti i sollevatori della serie 800 possono essere forniti anche in versione incassata.

La soluzione ottimale per l'ambiente di lavoro razionale:

- minimi ingombri a sollevatore alzato
- pavimento completamente libero nella posizione tutto basso.

All 800 series lifts can be supplied for recessed installation.

The best solution for a rational workshop:

- space saving when lift is raised
- obstacle free floor space when lift is fully lowered.

Alle Hebebühnen der Serie 800 können auch in Unterflur-Version geliefert werden.

Die optimale Lösung für den rationalen Arbeitsraum:

- Minimale Ausmaße bei angehobener Hebebühne
- Bodeneben und vollständig frei in der untersten Position.

Tous les ponts élévateurs de la série 800 peuvent être fournis en version encastrée dans le sol.

La solution optimale pour le milieu de travail rationnel:

- encombrement mini lorsque le pont est levé.
- sol entièrement libre lorsque le pont est en bas.

Todos los elevadores de la serie 800 se encuentran disponibles en versión empotrada.

La mejor solución para el ambiente de trabajo racional:

- mínimo espacio ocupado cuando el elevador está levantado.
- suelo completamente libre cuando el elevador está en posición todo bajo.



	Portata Capacity Trafähigkeit Capacité Capacidad	Lunghezza pedane Long platforms Plattformlänge Longues plateformes Plataformas largas
	kg	mm
RAV 825.8I	25.000	8.000
RAV 825.9I	25.000	9.000
RAV 825.10I	25.000	10.000
RAV 835.9I	35.000	9.000
RAV 835.10I	35.000	10.000
RAV 835.13I	35.000	13.000
RAV 825.10AI	25.000	10.000
RAV 835.10AI	35.000	10.000

PIT CLOSING - SPECIAL VERSION UPON REQUEST

- VAR5800.8A1 (→ RAV825.8I)
VAR5800.9A1 (→ RAV825.9I, RAV835.9I, RAV825.10AI, RAV835.10AI)
VAR5800.10A1 (→ RAV825.10I, RAV835.10I)
VAR5800.13A1 (→ RAV835.13I)

Dispositivo chiusura fossa.

Pit closing platforms.

Bodenausgleich.

Dispositif de fermeture de la fosse.

Dispositivo de cierre de la obra civil.

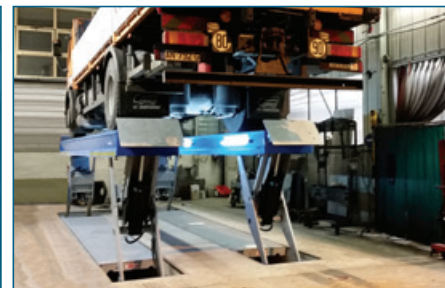
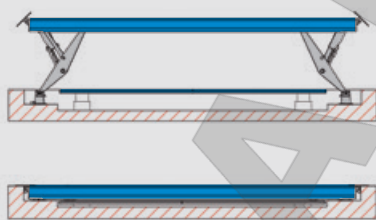

VAR5800/DUO

Esiste la possibilità di abbinare due ponti per farli funzionare:

- in modo sincronizzato, quindi con pedane sempre alla stessa altezza
- in modo singolo, quindi separatamente l'uno dall'altro con pedane ad altezze diverse

Two lifts can be twinned as follows:

- synchronised, therefore with the two lift platforms working at the same height;
- in single mode, therefore with the two lifts working independently with platforms at different height

Es besteht die Möglichkeit diese Modelle miteinander zu koppeln, um diese:

- synchron zu schalten; d.h. die Fahrschienen sind immer auf der gleichen Höhe
- einzel zu schalten; d.h. von einander getrennt mit Fahrschienen auf verschiedenen Höhen

Il est possible de jumeler 2 ponts afin de les faire fonctionner:

- de façon synchronisée, c'est-à-dire avec chemins de roulement toujours à la même hauteur
- ou de façon non-synchronisée, permettant ainsi des hauteurs différentes des chemins de roulement

Esiste la possibilità de acoplar dos elevadores para que funcionen:

- en modo sincronizado (los dos elevadores a la vez)
- en modo individual (independientes, tendríamos dos elevadores)



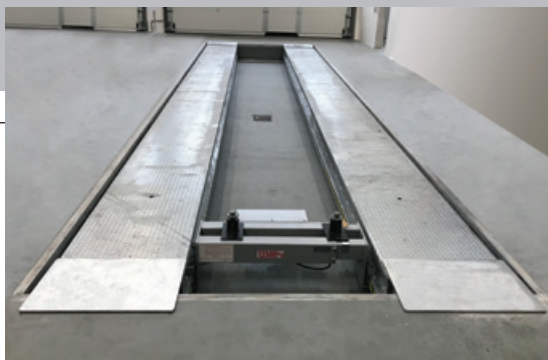

GALVANIZED SPECIAL VERSION

Versione zincata.
 Galvanized version.
 Feuerverzinkte Ausführung.
 Version galvanisée.
 Version galvanizada.

VAR800WPA2 WASH BAY VERSION

Versione da lavaggio.
 Componenti elettrici IP67.
 Version for wash bay.
 IP67 electrical components.
 Waschraumausführung.
 Elektrische Bestandteile IP67 geschützt.
 Version pour aire de lavage.
 Composants électriques en IP67
 Versión para lavado.
 Componentes eléctricos IP67.

Scatola comandi resistente all'acqua.
 Waterproof control unit.
 Spritzwasser-geschützter Steuerkasten.
 Boîtier de commande résistant à l'eau
 Caja de mando resistente al agua.

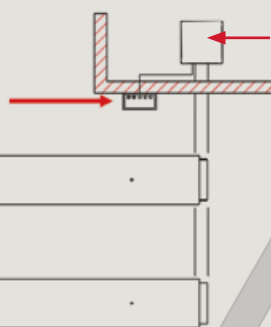

Centralina idraulica in un altro locale.
 Motor-pump unit in a separate room.
 Hydraulikaggregat in getrenntem Nebenraum.
 Pupitre hydraulique installé dans un local séparé
 Centralita hidráulica ubicada en otra habitación.

OPTIONS

Verdere documentazione specifica - See special technical specifications - Siehe spezifische Unterlagen. Voir documentation spécifique - Consultar documentación específica

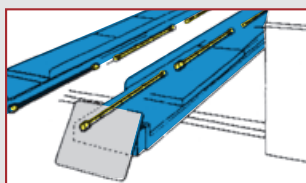

VAR5800A2 (2+2 neon)
VAR5800A5 (3+3 neon) (→13m)
 Impianto di illuminazione
 Lighting kit
 Beleuchtung
 Système d'éclairage
 Instalación de alumbrado



KP118PY - 13.500 kg
air hydraulic 6-10 bar
 Idropneumatica
 Air-hydraulic
 Lufthydraulisch
 Hydro-pneumatique
 Neumohidráulico

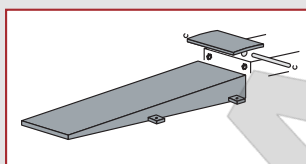

S720A3 - L= 3300 mm
 Rampe di salita lunghe.
 Longer run-up ramps.
 Längere Auffahrampen.
 Rampes d'accès longues.
 Rampas de subida largas.



Standard Accessories

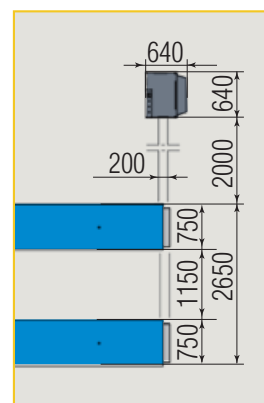

Posizione standard centralina
Power unit standard position

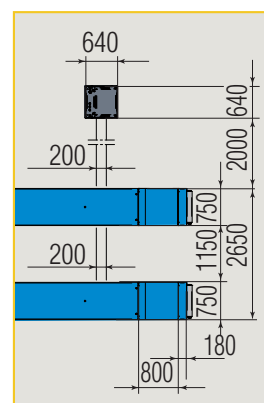





Versioni A Models A



Ravaglioli

COMPANY WITH
QUALITY SYSTEM
CERTIFIED BY DNV GL
= ISO 9001 =

COLONNE MOBILI PER TRATTORI 
MOBILE COLUMN LIFTS FOR TRACTORS 
MOBILE RADGREIFER-HEBEBÖCKE FÜR TRAKTOREN 
COLONNES MOBILES POUR TRACTEURS 
COLUMNAS MÓVILES PARA TRACTORES 

RAV

**262
AGR**

RAV

**308H.2
AGR**

Coppia di colonne mobili per trattori.
Le colonne sono equipaggiate con gli adattatori frontali e posteriori S300A2.
Accesso perfetto al veicolo.
Permettono servizio pneumatici e freni.

*Pair of mobile columns to raise different tractors.
The columns are equipped with S300A2 front and rear adapters.
Perfect access to the vehicle.
Allows tire and brake service.*

Hebeböcke zum Anheben verschiedener Traktoren.
Im Lieferumfang einhalten ist ein vorderer und hinterer Traktoradapter (S300A2).
Idealer Zugang am Fahrzeug.
Perfekt geeignet für Wartungs- und Reparaturarbeiten an den Rädern.

*Paire de colonnes mobiles pour soulever différents tracteurs.
Les colonnes sont équipées avec S300A2 avant et arrière adaptateurs.
Accessibilité parfaite au véhicule.
Il permet le service pneus et freins.
Avant et arrière jeu d'adaptateurs.*

Par de columnas aptas a levantar diferentes tipos de tractores.
Las columnas están equipadas con adaptadores delanteros y traseros S300A2.
Acceso perfecto al vehículo.
Facilitan los servicio de frenos y ruedas.
Juego de adaptadores delantero y trasero.

RAV 262 AGR

Colonne mobili elettromeccaniche
Electro-mechanical mobile column lifts
Elektro-Mechanische, mobile Radgreifer-Hebeböcke
Colonnes mobiles electromecaniques
Columnas móviles electromecánicas

ELECTRO-MECHANICAL

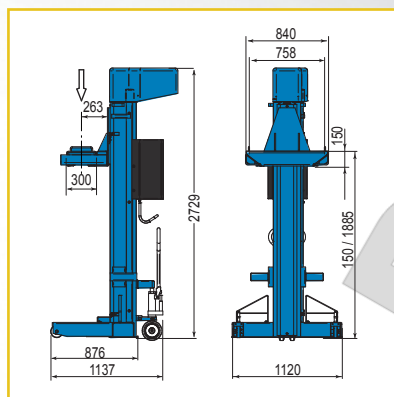

DATI TECNICI	TECHNICAL DATA	TECHNISCHE DATEN	DONNEES TECHNIQUES	DATOS TÉCNICOS		RAV 262 AGR
Portata per colonna	Capacity per column	Tragfähigkeit je Säule	Capacité par colonne	Capacidad por columna	kg	8500
Motore	Motor	Motor	Moteur	Motor	kW	3,7
Potenza minima di rete per colonna	Required mains power per column	Mindestnetzleistung je Säule	Puissance de réseau minimale par colonne	Potencia mínima de red por columna	400v 50 Hz	6 kW 9,5 A
Peso col principale	Master col weight	Hauptsäule - Gewicht	Poids col principale	Peso col principal	kg	510
Peso col secondaria	Slave col weight	Nebensäule - Gewicht	Poids col secondaire	Peso col secundaria	kg	460
Tempo salita	Rise time	Hubzeit	Temps de levage	Tiempo de subida		135"



Supporto base + distanziale + boccola +



Supporto base + accessorio con



Supporto posteriore con



ELECTRO-HYDRAULIC
WIRELESS

RAV 308H.2 AGR

Colonne mobili elettro-idrauliche

Electro-hydraulic mobile column lifts

Elektro-Hydraulische, mobile Radgreifer-Hebeböcke

Ponts éleveurs electro-hydrauliques à colonnes mobiles

Elevadores electro hidráulicos de columnas independientes

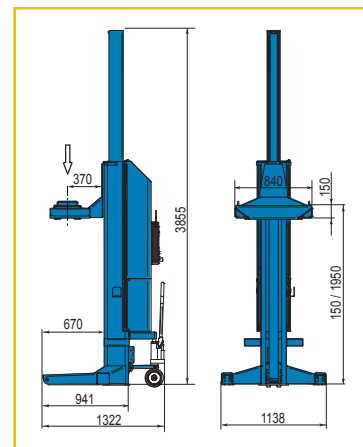

DATI TECNICI	TECHNICAL DATA	TECHNISCHE DATEN	DONNEES TECHNIQUES	DATOS TÉCNICOS	RAV 308H.2AGR
Portata per colonna	Capacity per column	Tragfähigkeit je Säule	Capacité par colonne	Capacidad por columna	8500 kg
Motore	Motor	Motor	Moteur	Motor	3 kW
Peso colonna	Column weight	Gewicht	Poids colonne	Peso columna	670 kg
Tempo salita	Rise time	Hubzeit	Temps de levage	Tiempo de subida	120"
Tempo discesa	Lowering time	Senkzeit	Temps de descente	Tiempo de bajada	70"

INCLUDED STANDARD (2 x kit)

 Supporto base
 Base support

 Boccia
 Bushing

 Supporto anteriore
 Front support

 Supporto anteriore
 piano bugnato
 Front support with
 rusticated surface

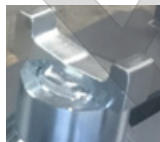
 Distanziale
 Spacer

 Supporto superiore
 con trattenimenti
 laterali
 Upper support with
 holding sides

 Tampone circolare
 con gomma
 Round support with
 rubber surface

INCLUDED STANDARD (1 x kit)

 Supporto posteriore con
 barre di trattenimento anti-
 ribaltamento
 Rear adapter with anti-
 tilting holding bars



Ravaglioli

RAV
L Version

COMPANY WITH QUALITY MANAGEMENT
SYSTEM CERTIFIED BY DNV
= ISO 9001:2008 =

**RAV240L SERIES
RAV260L SERIES
RAV270L SERIES**

**LARGE FORK
MAX DIAMETER 1600 mm**

Per diametro ruota massimo 1600 mm.

For max wheel diameter 1600 mm.

Für max Raddurchmesser 1600 mm.

Pour diamètre maxi de roue 1600 mm.

Para diametro máximo rueda 1600 mm.

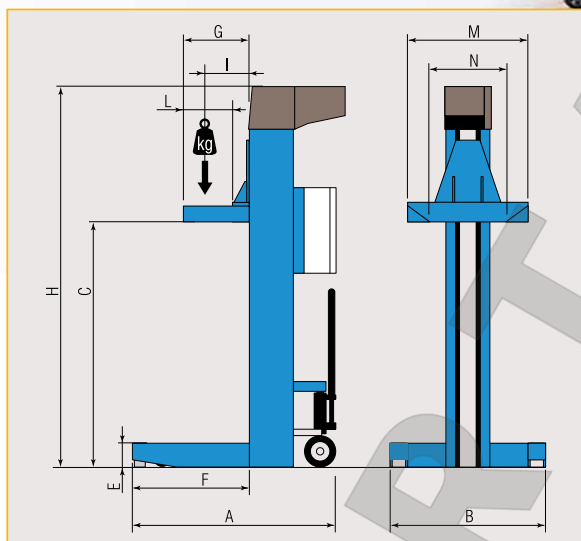

DIMENSIONI / DIMENSIONS / ABMESSUNGEN / DIMENSIONS / DIMENSIONES (mm)											
	A	B	C	E	F	G	H	I	L	M	N
RAV241L	1241	1260	1756	151	652	544	2674	350	405	990	726
RAV261L	1180	1280	1763	153			2725	315			
RAV271L	1100	1272	1810	141	532	440	2730	290	315		

DATI TECNICI	TECHNICAL DATA	TECHNISCHE DATEN	DONNEES TECHNIQUES	DATOS TÉCNICOS		RAV 241L	RAV 261L	RAV 271L
Portata per colonna	Capacity per column	Tragfähigkeit je Säule	Capacité par colonne	Capacidad por columna	kg	7000	8500	10000
Motore	Motor	Motor	Moteur	Motor	kW	2,4	3,7	3,7
Potenza minima di rete per colonna	Required mains power per column	Mindestnetzleistung je Säule	Puissance de réseau minimale par colonne	Potencia mínima de red por columna	400v/50 Hz	5 kW-8,5 A	6 kW-9,5 A	6,5 kW-10,5 A
Peso colonna principale	Master column weight	Hauptsäule - Gewicht	Poids colonne principale	Peso columna principal	kg	470	510	650
Peso colonna secondaria	Slave column weight	Nebensäule - Gewicht	Poids colonne secondaire	Peso columna secundaria	kg	455	490	630
Tempo salita	Rise time	Hubzeit	Temps de levage	Tiempo de subida		135"	135"	180"
Ø max. pneumatico	Maximum tyre diameter	Max. Reifendurchmesser	Diamètre max. du pneu.	Diámetro máximo neumático	mm	1600	1600	1600
Ø min. pneumatico	Minimum tyre diameter	Min. Reifendurchmesser	Diamètre min. du pneu.	Diámetro mínimo neumático	mm	1200	1200	1200
Ø min. cerchio	Minimum rim diameter	Min. Felgendurchmesser	Diamètre min. de la jante	Diámetro mínimo llanta	mm	730	730	730

CONFIGURAZIONI - CONFIGURATIONS - KONFIGURATIONEN - CONFIGURATIONNE - CONFIGURACIONES

SERIE	Portata per colonna Capacity per column Tragfähigkeit je Säule Capacité par colonne Capacidad por columna	4 colonne / columns / Säulen colonnes / columnas	6 colonne / columns / Säulen colonnes / columnas	8 colonne / columns / Säulen colonnes / columnas
RAV 240	kg 7000	RAV 241 L	RAV 243 L	RAV 245 L
RAV 260	kg 8500	RAV 261 L	RAV 263 L	RAV 265 L

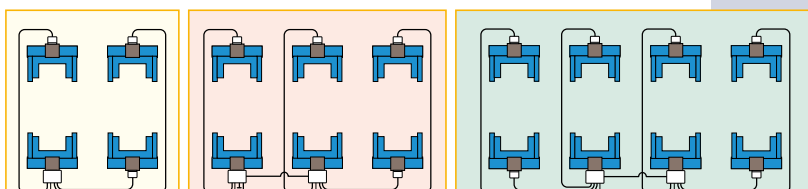

RAV271 VS603

X-LARGE FORK MAX DIAMETER 2000 mm MAX WHEEL WIDTH 750 mm

Per diametro ruota massimo 2000 mm.
Portata per colonna 8000 kg.

For max wheel diameter 2000 mm.
Capacity per column 8000 kg.

Für max Raddurchmesser 2000 mm.
Tragfähigkeit je Säule 8000 kg.

Pour diamètre maxi de roue 2000 mm.
Capacité par colonne 8000 kg.

Para diametro maximo rueda 2000 mm.
Capacidad por columna 8000 kg.

Versione speciale a richiesta
Special version on demand
Version auf Anfrage
version sur demande
Versión bajo pedido





Ravaglioli

RAV U Version

COMPANY WITH QUALITY MANAGEMENT
SYSTEM CERTIFIED BY DNV
= ISO 9001:2008 =

U VERSION

VAR240/U
(→ RAV 240-260 SERIES)

VAR 270/U
(→ RAV 270 SERIES)

Carrello universale predisposto per il montaggio di supporti speciali per l'utilizzo in particolari condizioni come il sollevamento di mezzi su rotaia.

Universal carriage for fitting of customized pick-up adapters for use in special conditions such as lifting of rolling stock.

Universallhubwagen, ausgelegt für die Montage von Sonderaufnahmen für spezielle Anwendungen wie das Anheben von Schienenbeförderungsmitteln.

Chariot universel prédisposé pour le montage de supports spéciaux pour l'emploi dans des conditions particulières, comme le levage des moyens de transport sur rails.

Carro universal predisposto para el montaje de soportes especiales útiles en condiciones particulares como la elevación de medios sobre raíles.



Possibilità di utilizzo di supporti particolari, standard o speciali a richiesta.

Universal carriages offer the possibility of using standard or customs made pick-up adapters.

Möglichkeit, Sonderaufnahmen zu verwenden (standard oder spezielle auf Anfrage).

Possibilità d'utiliser des supports standards ou construits sur demande.

Posibilidad de uso de soportes particulares standard o especiales bajo pedido.

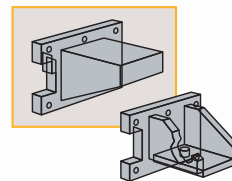
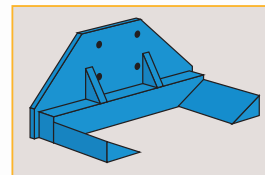
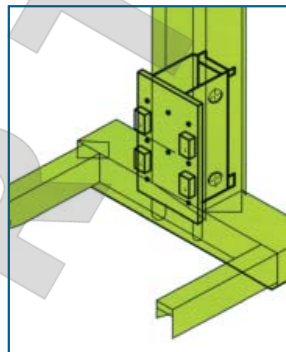

SPECIAL VERSION (on request)
Max 16 columns operation





Top product - Made in Italy
Italienisches Spitzenprodukt
L'excelence du produit "Fabriqué en Italie"
Excelencia del producto "Hecho en Italia"

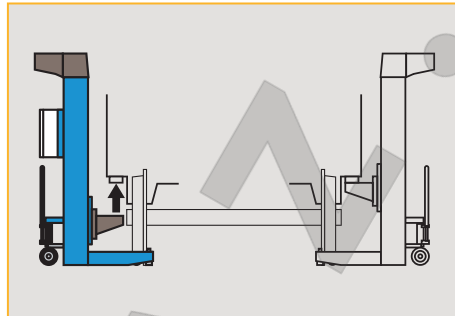
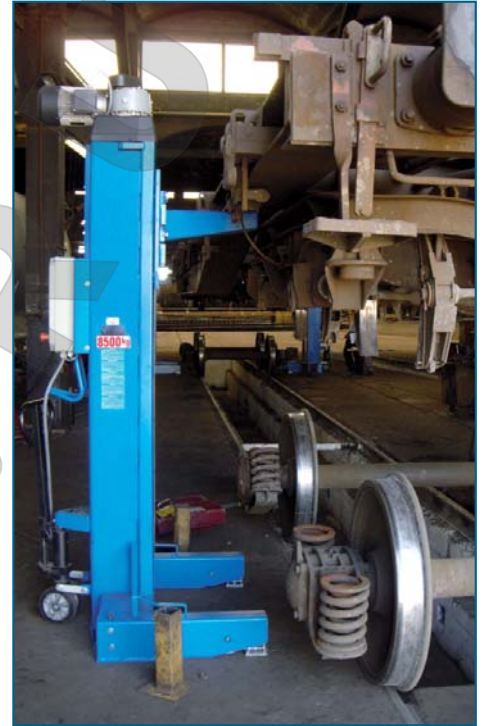

OPTIONS

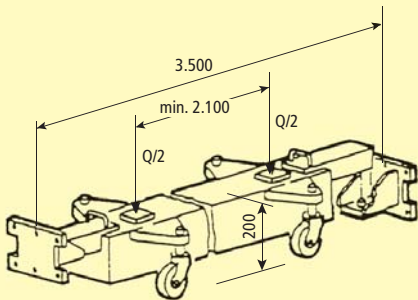

S260UA1 15.000 kg

S270UA1 20.000 kg

Traverse per il sollevamento
assale a ruote libere.

Cross beams for wheel-free
axle lifting.

Quertraverse.

Traverses de levage du chassis.

Traviesas de elevación eje.

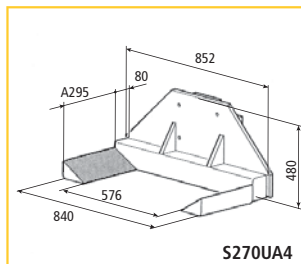
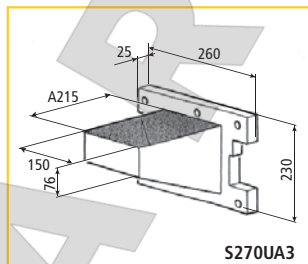
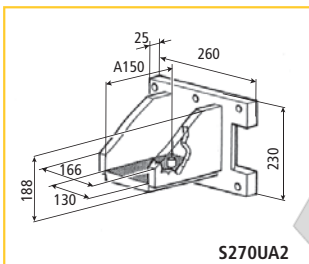

Supporti
Lifting brackets
Aufnahme
Étrier
Soportes

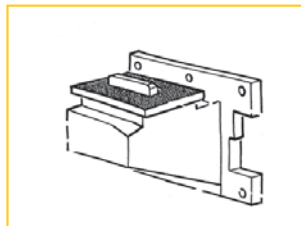
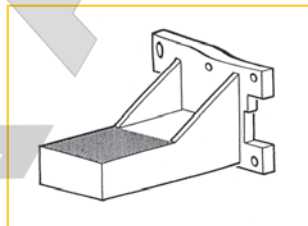
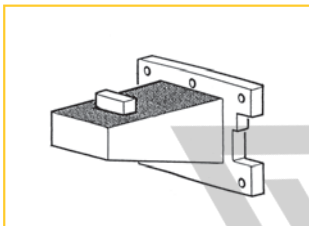

Versione speciale a richiesta
Special version on demand
Version auf Anfrage
version sur demande
Versión bajo pedido



Ravaglioli

RAV
C Version

COMPANY WITH QUALITY MANAGEMENT
 SYSTEM CERTIFIED BY DNV
 = ISO 9001:2008 =

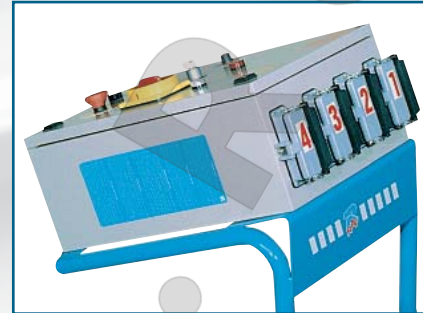

Consolle di comando carrellata.
 Separate control unit on wheels.
 Verfahrbare Steuerkonsole.
 Pupitre de commande sur chariot.
 Consola de mando movil.

C VERSION

Tutti i dispositivi di selezione sono sulla consolle e solo da questa sono attivabili i comandi in collettivo delle colonne selezionate.

All selection controls for operation of all selected columns are on the control unit.

Sämtliche Selektiereinrichtungen sind auf der Steuerkonsole angeordnet und nur über diese Konsole sind die Kollektivsteuerungen der selektierten Säulen aktivierbar.

Tous les contrôles se trouvent sur le pupitre, d'ou commander le fonctionnement collectif des colonnes.

Todos los dispositivos de selección están en la consola y solamente desde esta se pueden activar los mandos colectivos de las columnas seleccionadas.



Le colonne sono tutte uguali, dotate di quadro elettrico secondario per azionare il solo comando in singolo per il preposizionamento.

All columns are the same, equipped with a secondary control box to operate each column independently for pre-setting purposes.

Die Säulen sind alle gleich und mit einem Sekundärschaltschrank versehen. Über diesen Schaltschrank ist nur der Einzelbetrieb für die Vorpositionierung zum Hochfahren steuerbar.

Les colonnes sont toutes identiques et sont équipées d'un tableau électrique secondaire pour l'actionnement individuel de prépositionnement au levage.

Las columnas son todas iguales y tienen un cuadro eléctrico secundario para accionar el mando individual de preposicionamiento.

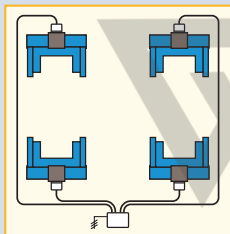

4 colonne / columns / Säulen / colonnes / columnas

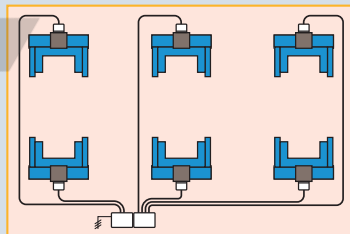

6 colonne / columns / Säulen / colonnes / columnas

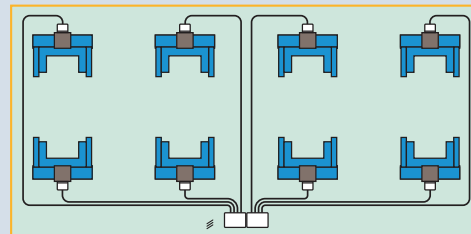

8 colonne / columns / Säulen / colonnes / columnas



COMPANY WITH QUALITY MANAGEMENT
SYSTEM CERTIFIED BY DNV
= ISO 9001:2008 =

RAV
212NC



 MOTOR: 3 ph. - 230/400V - 50Hz - 3,0 kW

RAV212NC - MOBILE HOME

Versione speciale per veicoli commerciali leggeri e camper.
Portata 2.500Kg per colonna, per interno.
Special version for light commercial vehicles and mobile homes.
2.500Kg capacity per column, for indoor use.
Sonderversion für LLKW und Wohnmobile.
Tragfähigkeit 2.500 kg je Säule, in Werkstatthallen.
Version spéciale pour VU et camping car.
Capacité 2.500 kg par colonne, pour intérieur.
Versión especial para vehículos comerciales ligeros y caravanas.
Capacidad 2.500 kg por columna, para interior.





Top product - Made in Italy
Italienisches Spitzenprodukt
L'excellence du produit "Fabriqué en Italie"
Excelencia del producto "Hecho en Italia"

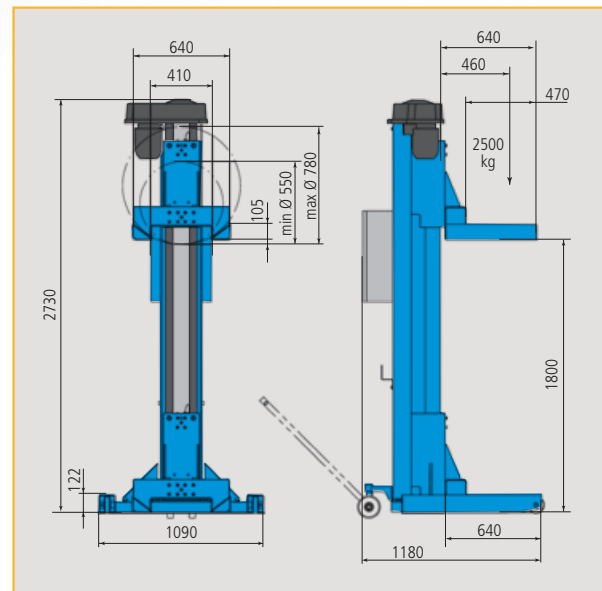
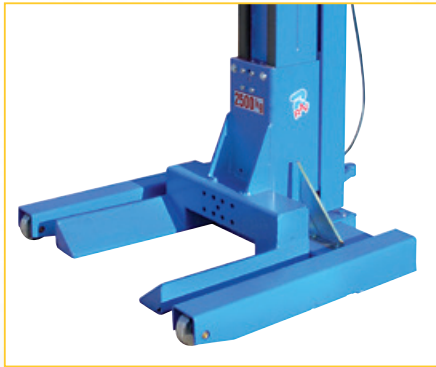



Ravaglioli

COMPANY WITH
QUALITY SYSTEM
CERTIFIED BY DNV GL
= ISO 9001 =

PONTI A PISTONI PER CAMION 

IN GROUND TRUCK LIFTS 

LKW-STEMPELHEBEBÜHNEN 

PONTS À FÛTS ENCASTRÉS POIDS-LOURDS 

ELEVADORES DE PISTONES PARA VEHÍCULOS INDUSTRIALES 

RAV
2150
SERIES



SINCE 1958



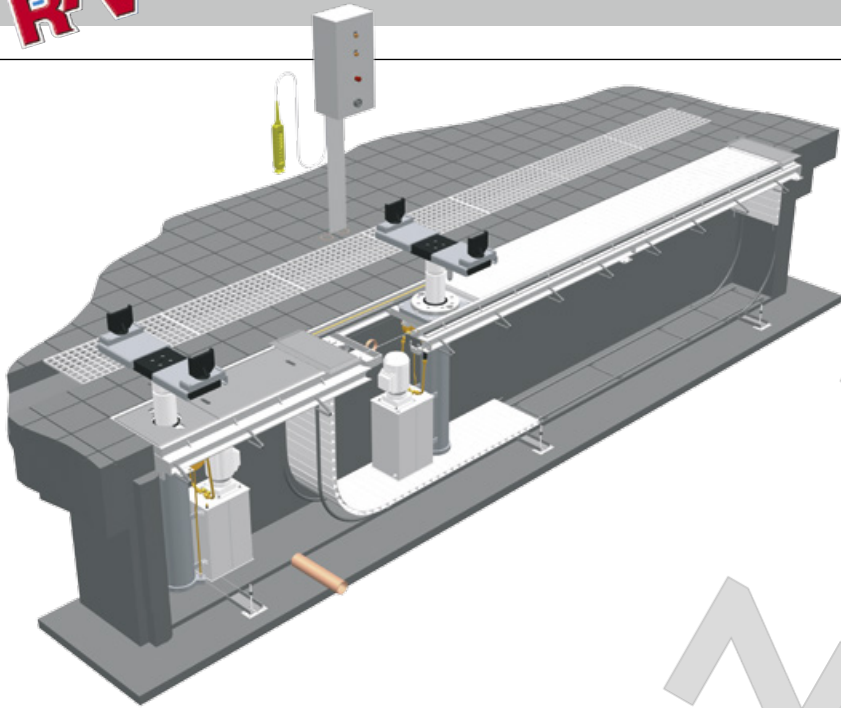

DOPPIA SICUREZZA

Il pistone esterno ha solo compiti di sollevamento e di abbassamento. Il secondo, quello che si trova all'interno, ha esclusivamente funzione di sicurezza. Entrambi i cilindri sono separati ermeticamente l'uno dall'altro per mezzo di circuiti idraulici indipendenti. Il sistema costruttivo integrato del sostegno di sicurezza ha inoltre l'enorme vantaggio di essere una protezione completa nei confronti di sporco e corrosione.

DOUBLE SAFETY

The outer cylinder serves exclusively for lifting and lowering. The inner-lying, second cylinder cares exclusively for safety. Both cylinders are hermetically separated from one another by two independent hydraulic circuits. Furthermore, the integrated construction of the safety device has the enormous advantage of being completely protected against dirt and corrosion.

SICHERHEIT MAL ZWEI

Der äußere Zylinder steht ausschließlich für Hebe- und Senkaufgaben zur Verfügung. Der innenliegende zweite Zylinder dient ausschließlich der Sicherheit. Beide Zylinder sind durch zwei unabhängige Hydraulikkreisläufe hermetisch voneinander getrennt. Die integrierte Bauweise der Sicherheitsabstützung besitzt zudem den enormen Vorteil eines vollständigen Schutzes vor Schmutzpartikel und Korrosion.



DOUBLE SÉCURITÉ

Le cylindre extérieur n'est disponible que pour les travaux de levage et de descente. Le deuxième cylindre se trouvant à l'intérieur sert uniquement à la sécurité. Les deux cylindres sont séparés hermétiquement l'un de l'autre par deux circuits hydrauliques indépendants. Le principe de construction intégrée du cylindre de sécurité intérieure dispose en plus de l'énorme avantage d'une protection totale contre la corrosion.

DOBLE SEGURIDAD

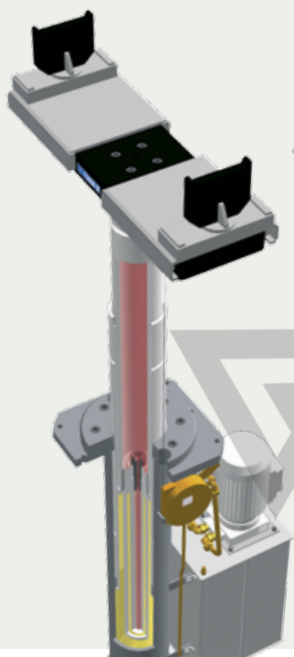
El cilindro exterior está dispuesto exclusivamente para las funciones de elevación y descenso. El segundo cilindro, dispuesto en el interior, sirve únicamente como seguridad. Ambos cilindros están separados herméticamente el uno del otro mediante dos circuitos hidráulicos independientes. El principio de construcción del apoyo de seguridad integrado ofrece, además, la enorme ventaja de estar protegido completamente contra suciedad y corrosión.



-  Lavoro (cilindro si sollevamento)
Operation (lifting cylinder)
Arbeiten (Hubzylinder)
Travaux (cylindre de levage)
Trabajo (cilindro de elevación)
-  Sicurezza (cilindro di sicurezza)
Safety (safety cylinder)
Sicherheit (Sicherheitszylinder)
Sécurité (cylindre de sécurité)
Seguridad (cilindro de seguridad)

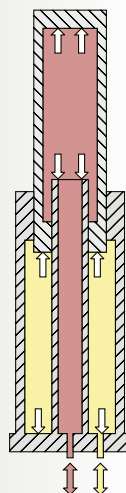



RAV2150.4

Con 4 pistoni e 2 pannelli comando si possono sollevare separatamente anche due veicoli. Il sistema di comando sincronizzato fa sì che il rendimento massimo si ottenga soltanto con un camion a rimorchio.

RAV2150.3

Oltre alle possibilità di impiego che già offrono i 2 pistoni, il modello a 3 pistoni è fondamentale per autoarticolati e bus articolati.

RAV2150.2

Il modello a 2 pistoni è il partner ideale quando si tratta di sollevare trattori, camion e bus.

RAV2150.4

With 4 posts and 2 hand-held control panels it is also possible to lift 2 vehicles separately. Due to synchronisation control as standard, the full capacity of supply can be seen clearly when truck and trailer are lifted together.

RAV2150.3

In addition to the application possibilities which the 2-post lifts already offer, the 3-post execution is necessary for semi-trailers and articulated busses.

RAV2150.2

The 2-post execution is the ideal choice for lifting trucks and busses.

RAV2150.4

Mit 4 Stempeln und 2 Bedientableaus lassen sich schnell einmal auch zwei Fahrzeuge separat anheben. Aufgrund der serienmäßigen Gleichlaufsteuerung wird der volle Leistungsumfang erst bei einem Lkw mit Anhänger richtig deutlich.

RAV2150.3

Neben den Einsatzmöglichkeiten, die 2 Stempel bereits bieten, ist die 3-Stempel-Ausführung für Sattelzüge und Gelenkbusse Voraussetzung.

RAV2150.2

Die 2-Stempel-Ausführung ist der ideale Partner, wenn es um die Aufnahme von Zugmaschinen, Lkw oder Bussen geht.

RAV2150.4

Avec 4 vérins et 2 pupitres de commandes mobiles, 2 véhicules peuvent être levés rapidement et séparément. Grâce à son iso-nivelage en série toutes les capacités sont mises en valeur lors du levage d'un camion-remorque.

RAV2150.3

En plus des possibilités d'utilisation classique, le modèle à 3 vérins est obligatoire pour les semi-remorques et les autobus articulés.

RAV2150.2

Le premier modèle de la gamme est la solution parfaite pour le levage des tracteurs, porteurs ou autobus.

RAV2150.4

Gracias a sus 4 pistones y 2 cuadros de mando se pueden levantar 2 vehículos diferentes al mismo tiempo. Además, su mando de funcionamiento sincrónico de serie facilita la elevación completa de un camión con remolque

RAV2150.3

Junto a las posibilidades que ya ofrecen los 2 pistones, la versión de 3 pistones es necesaria para manipular semirremolques y autobuses articulados.

RAV2150.2

La versión de 2 pistones es ideal para la elevación de cabezas tractoras, camiones o autobuses.



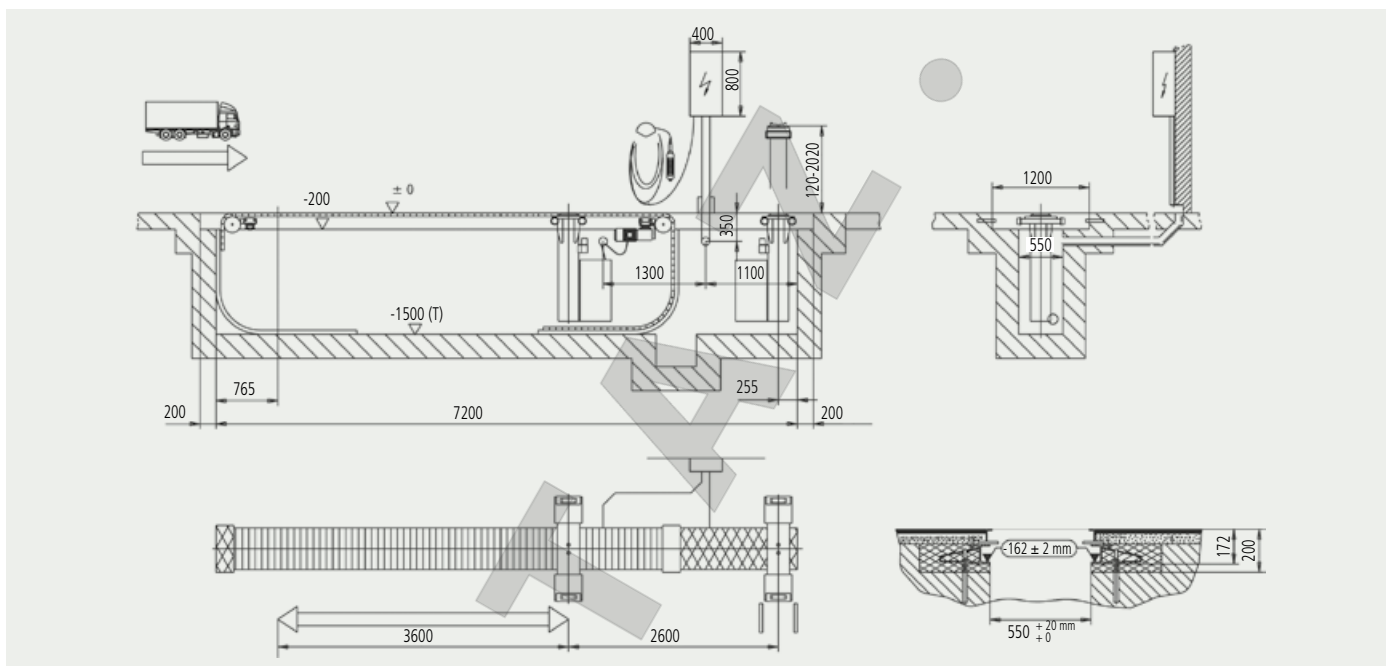

DATI TECNICI	TECHNICAL DATA	TECHNISCHE DATEN	DONNEES TECHNIQUES	DATOS TÉCNICOS		2150.2R	2150.2W	2150.3R	2150.3W	2150.4R	2150.4W
Cilindri	Cylinders	Hubzylinder	Cylindres	Cilindros		2	2	3	3	4	4
Cilindri mobili	Moveable cylinders	Verfahrbare Hubzylinder	Cylindres mobiles	Cilindros móviles		1	1	2	2	3	3
Corsa	Stroke	Hub	Course	Elevación	mm	1900					
Portata	Capacity	Tragfähigkeit	Capacité	Capacidad	t	2x15	2x15	3x15	3x15	4x15	4x15
Lunghezza	Length	Länge	Longueur	Longitud	mm	7290	7290	14580	14580	20740	20740
Profondità con telaio	Depth with frame	Einbautiefe mit Rahmen	Profondeur avec cadre	Profundidad con marco	mm	1400	-	1400	-	1400	-
Profondità con cassetta	Depth with cassette	Einbautiefe mit Wanne	Profondeur avec cassette	Profundidad con caja	mm	-	1450	-	1450	-	1450
Tempo di salita	Lifting time	Hubzeit	Temps de levage	Tiempo de elevación	s	85					
Tempo di discesa	Lowering time	Senkzeit	Temps d'abaissement	Tiempo de descenso	s	72					
Olio per cilindro	Oil filling per lifting unit	Ölfüllung je Zylinder	Remplissage d'huile par vérin	Vol. aceite por unid. elev.	l	55					

I dati di ingombro sono da confermare per ogni installazione.

R = include un telaio da montare su fossa in cemento già predisposta
W = include una cassetta completa da inserire nel pavimento

All dimensions to be confirmed for each installation.

R = includes the upper frame to be mounted over a specific pit
W = includes the complete cassette for inground installation

Aufstellungs- bzw. Montage Maße müssen bei jeder Neuinstallation angegeben werden

R= berücksichtigt eine Verschalung, die einbetoniert werden muß
W= berücksichtigt eine Kassetten, die im Boden einbetoniert werden muß

Les données d'encombrement doivent être confirmées avant chaque installation

R = Comprend un cadre pour le montage sur une fosse en béton déjà predisposée
W = Comprend une cassette complète à insérer dans la fosse

Hay que confirmar previamente todas las dimensiones de la obra civil de cada instalación

R = incluye un marco para montar encima del foso de hormigón ya predisposto
W = incluye una caja completa para insertar en el foso

По вопросам продаж и поддержки обращайтесь:

Алматы (7273)495-231	Казань (843)206-01-48	Новокузнецк (3843)20-46-81	Смоленск (4812)29-41-54
Архангельск (8182)63-90-72	Калининград (4012)72-03-81	Новосибирск (383)227-86-73	Сочи (862)225-72-31
Астрахань (8512)99-46-04	Калуга (4842)92-23-67	Омск (3812)21-46-40	Ставрополь (8652)20-65-13
Барнаул (3852)73-04-60	Кемерово (3842)65-04-62	Орел (4862)44-53-42	Сургут (3462)77-98-35
Белгород (4722)40-23-64	Киров (8332)68-02-04	Оренбург (3532)37-68-04	Тверь (4822)63-31-35
Брянск (4832)59-03-52	Краснодар (861)203-40-90	Пенза (8412)22-31-16	Томск (3822)98-41-53
Владивосток (423)249-28-31	Красноярск (391)204-63-61	Пермь (342)205-81-47	Тула (4872)74-02-29
Волгоград (844)278-03-48	Курск (4712)77-13-04	Ростов-на-Дону (863)308-18-15	Тюмень (3452)66-21-18
Вологда (8172)26-41-59	Липецк (4742)52-20-81	Рязань (4912)46-61-64	Ульяновск (8422)24-23-59
Воронеж (473)204-51-73	Магнитогорск (3519)55-03-13	Самара (846)206-03-16	Уфа (347)229-48-12
Екатеринбург (343)384-55-89	Москва (495)268-04-70	Санкт-Петербург (812)309-46-40	Хабаровск (4212)92-98-04
Иваново (4932)77-34-06	Мурманск (8152)59-64-93	Саратов (845)249-38-78	Челябинск (351)202-03-61
Ижевск (3412)26-03-58	Набережные Челны (8552)20-53-41	Севастополь (8692)22-31-93	Череповец (8202)49-02-64
Иркутск (395)279-98-46	Нижний Новгород (831)429-08-12	Симферополь (3652)67-13-56	Ярославль (4852)69-52-93
Россия (495)268-04-70	Киргизия (996)312-96-26-47	Казахстан (7172)727-132	