



KITS



PUMPS



METERS



METERED NOZZLES



NOZZLES

WASTE OIL  
EQUIPMENTS

# VISCOMAT DC

## FEATURES

- BUILT-IN BYPASS
- SMALL SIZE
- EASY TO FIT
- MULTI-PURPOSE PUMP

VISCOMAT DC is oil transfer pump suitable for workshops with demanding work paces. Designed for applications where it is necessary to transfer oil from drums, where there is no connection to the power line or compressed air system, VISCOMAT DC can be applied to drums, IBC tanks or installed in kits for oil transfer like DRUM VISCOMAT.

### PERFORMANCE

UP TO

**10 L/MIN**

FLOW RATE

UP TO

**10 BAR**

PRESSURE

BELOW

**65 DB**

NOISE LEVEL\*\*

UP TO

**2000 CST**

VISCOSITY



VISCOMAT DC



### PACKAGING

CODE	WEIGHT		PACKAGING			
	KG	LBS	MM	INCH	PCS/PALLET	PCS/BOX
FO030902A	3	6,6	200X120X140	7,9X4,7X5,5		1
FO030901A	4,9	10,8	345X175X255	13,6X6,9X10		1
FO030900A	4,9	10,8	345X175X255	13,6X6,9X10		1
FO031002A	3	6,6	200X120X140	7,9X4,7X5,5		1
FO031001A	4,9	10,8	345X175X255	13,6X6,9X10		1
FO031000A	4,9	10,8	345X175X255	13,6X6,9X10		1
FO0311000	4,9	10,8	345X175X255	13,6X6,9X10		1
FO0311010	4,9	10,8	345X175X255	13,6X6,9X10		1

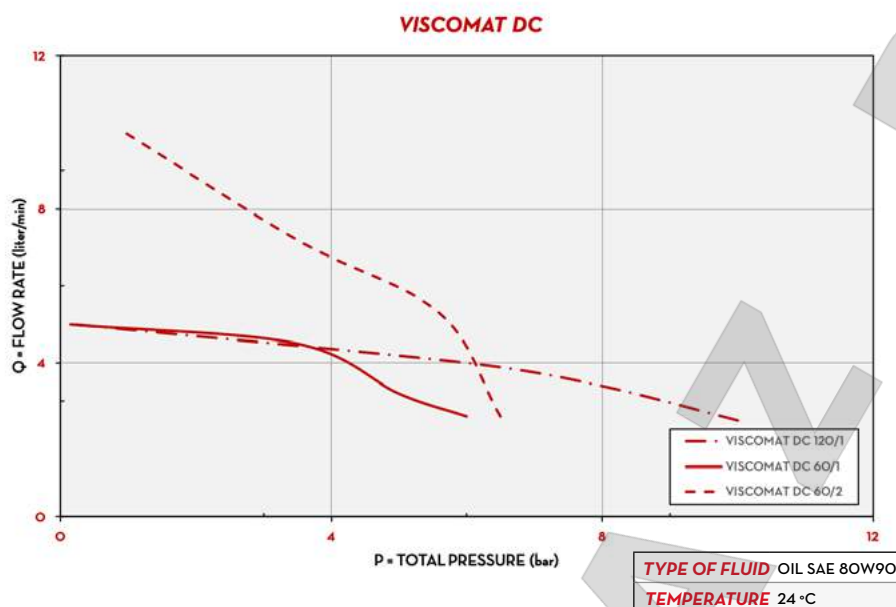
**CHART**

**IN THE BOX**

- VISCOMAT DC PUMP
- INSTRUCTION MANUAL

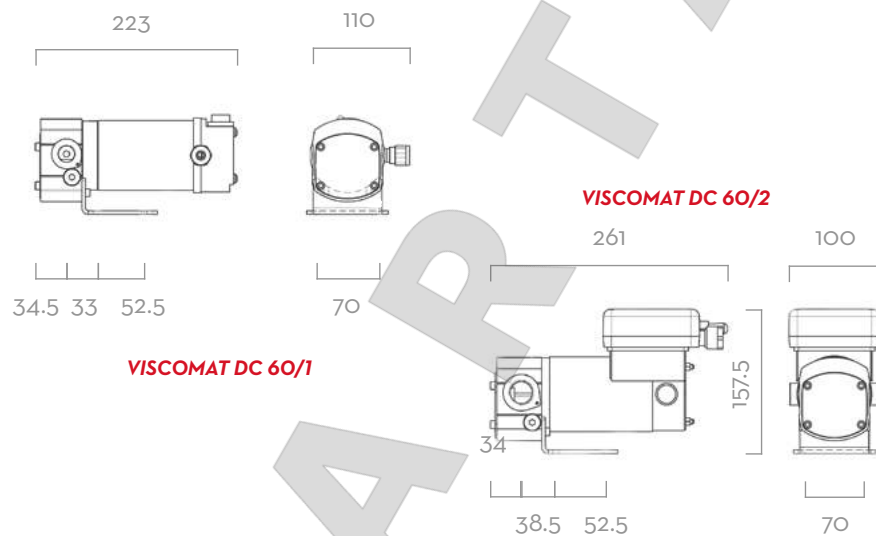
**DETAILS**

**DIMENSIONS**

Dimensions expressed in millimeters

**MATERIALS**

- BODY: CAST IRON
- GEARS: SINTERED STEEL
- SHAFT: STEEL
- BYPASS: BRASS

**TECHNICAL DATA**

CODE	DESCRIPTION	FLUIDS TYPE	FLOW RATE		WORKING PRESSURE		VOLTAGE			RPM	INLET OUTLET BSP	PRESSURE SWITCH
			L/MIN	GPM	BAR	PSI	MOTOR V./ HZ	POWER WATT	AMP. MAX.			
FO030902A	VISCOMAT 60/1 12V DC		4	1,2	5	70	12	150	18,5	2900	1/2" BSP	NO
FO030901A	VISCOMAT 60/2 12V DC (*)		10	2,8	4	57	12	300	35	2900	3/4" BSP	NO
FO030900A	VISCOMAT 120/1 12V DC		5	1,4	10	140	12	200	26,5	2900	1/2" BSP	NO
FO031002A	VISCOMAT 60/1 24V DC		4	1,2	5	70	24	150	9,5	2900	1/2" BSP	NO
FO031001A	VISCOMAT 60/2 24V DC (*)		10	2,8	4	57	24	300	18	2900	3/4" BSP	NO
FO031000A	VISCOMAT 120/1 24V DC		5	1,4	10	140	24	200	19,5	2900	1/2" BSP	NO
FO0311000	VISCOMAT 120/1 12V PST		5	1,4	10	140	12	200	22,5	2900	1/2" BSP	YES
FO0311010	VISCOMAT 120/1 24V PST		5	1,4	10	140	24	200	19,5	2900	1/2" BSP	YES

(\*) FOR VISCOMAT DC 60/2 MAX OIL VISCOSITY 600 CST - (\*\*) MEASURING MADE WITH PUMP ASSEMBLY COVERED BY FILM TAKEN FROM 1 METER DISTANCE WITHOUT ANY ENVIRONMENTAL NOISES