

LAUNCH

TLT240SC

Two Post Lift User's Manual

Version No:1605

WARNING



- This instruction manual is an essential integral part of this product. Please read all instructions.
- Properly keep this manual for use during the maintenance.
- This equipment is only used for its clearly designed purpose, and never use it for other purposes.
- The manufacturer is not responsible for any damage caused by improper use or other purposes of use.

PRECAUTION

- Only the qualified personnel having undergone special training can operate this machine. Without the permission of the manufacturer or not following the requirement of the manual, any changes in the machine part and in the usage scope may cause direct or indirect damage to the machine.
- Don't keep the lift in the extreme temperature and humidity environment. Avoid installation beside the heating equipment, water tap, air humidifier or stove.
- Prevent the lift from contacting large amount of dust, ammonia, alcohol, thinner or spray adhesive, and prevent it from rain shower.
- During the machine operation, non-operators should be kept away from the machine.

- Inspect machine daily ,do not use lift with damaged parts or being damaged .Use original components to replace damaged parts
- The lift can't be overloaded. The rated load of the lift is already marked on the nameplate.
- Please don't raise the lift when there are people in the vehicle. During the operation, the customer and spectators shouldn't stand in the lifting area.
- Keep the lifting area free from obstacle, grease, machine oil, garbage and other impurities.
- Position the swing arm of the lift, making it contact the lifting point as recommended by the manufacturer. Raise the carriage and confirm the lifting pad and vehicle are closely contacted. Raise the carriage to the appropriate working height.
- For some vehicles, the parts dismantling (or installation) will cause severe deviation of the center of gravity, leading to unstable vehicle. The support is needed to keep the balance of the vehicle.
- Before moving the vehicle away from the lifting area, please position the swing arm and lifting pad back away to avoid blockage during the movement.
- Use appropriate equipment and tools as well as safety protection facilities, e.g. working uniform, safety boot, etc.
- Pay special attention to various safety marks attached to the machine body.
- Keep hair, loose clothing, fingers, and all parts of body away from moving parts
- Pay special attention not to dismantling the safety unit of the machine or making it not functioning.
- The hydraulic oil used for this lift is N32 or N46. Please refer the safety data of grease and oil shown in the manual.
- Let components cool down before storage, loosen component cables completely in storage
- Do not install lift in the open air or expose to rain, special requirements should be offered to manufacturer if it can't be avoided.

Caution Labeling Exemplification

- (1) Read operating and safety manuals before using lift!



- (2) Proper maintenance and inspection are necessary for safe operation!



- (3) Do not operate a damaged lift!



- (4) Lift can be used by trained operators ONLY!



- (5) Only Authorized personnel can be in the lift area!



- (6) Use vehicle manufacturer commend lifting points!

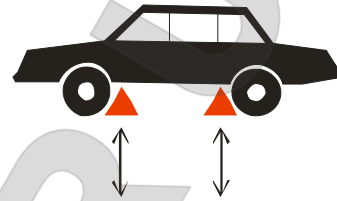

- (7) Use bracket to help disassembly or installation!



- (8) Auxiliary adapters would reduce load capacity!

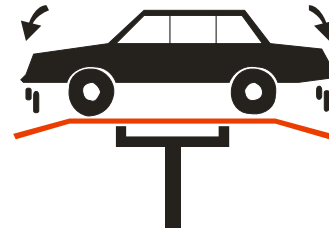

- (9) Area should be unimpeded in case of vehicle overturn!



- (10) The central of gravity should be between two arms!



(11) Keep area clear when lifting and lowering machine!



(14) Keep feet away when lowering lift!



(12) Do not shake the vehicle on the lift!



(15) Do not stand under carrying arms or other load carrying device while lift is being operated with load!



(13) Do not lift single side of vehicle!





Table of Contents

1. Outline	1
1.1 MODEL DESCRIPTION	1
1.2 PURPOSE	1
1.3 FUNCTIONS AND FEATURES	1
1.4 TECHNICAL SPECIFICATIONS	1
1.5 ENVIRONMENTAL REQUIREMENT	2
2. Lift Structure	2
2.1 LIFT STRUCTURES ARE SHOWN AS BELOW:	2
2.2 MAIN STRUCTURE PRINCIPLES:	4
3 Operation Descriptions	4
3.1 PRECAUTIONS FOR VEHICLE REPAIR WORK	4
3.2 PREPARATION BEFORE OPERATION	4
3.3 INSPECTION BEFORE OPERATION	4
3.4 LIFTING THE VEHICLE	4
3.5 LOWERING THE VEHICLE	5
4 Hydraulic and Electrical System of the Equipment	6
4.1 HYDRAULIC SYSTEM OF THE LIFT	6
4.2 ELECTRICAL SYSTEM OF THE LIFT	7
5 Solutions to FAQ	8
6. Repair and Maintenance	9
7. Storage and Scrap	10
7.1 STORAGE	10
7.2 SCRAP	10
8. Tools for Installation and Adjustment	10
9. Unpacking	10
10. Installation	11





10.1 IMPORTANT NOTICE	11
10.2 INSTALLATION PROCEDURE	11
10.2.1 Selecting installation site	11
10.2.2 Base plate layout.....	12
10.2.3 Install the power side column	13
10.2.4 Install the top beam	14
10.2.5 Install the offside column	18
10.2.6 Install and adjust the balancing steel cables	18
10.2.7 Install the power unit and hydraulic lines	18
10.2.8 Install the swing arm	19
11. Lift Adjustment	20
11.1 PREPARATION BEFORE THE ADJUSTMENT	20
11.2 ADJUSTMENT PROCEDURE	20
12. List of the Lift components	21
13 Packaging	27
Appendix: Transportation Guide	27
Grease and hydraulic oil for lift	28
Limited warranty	29



1. Outline

1.1 Model Description

Model	Description
TLT240SC clear-floor 2-post lift	4.0T clear-floor 2-post lift (Fig.1、 Fig.2、 Fig.3)

1.2 Purpose

This machine is applicable for the lifting of various small and medium-sized vehicles with total weight below 4.0t in garage and workshop.

- Top limit switch, effectively protecting the vehicle from overhead collision.
- Dual hydraulic cylinders drive, stable lifting and lowering.
- Manual lowering, safe and simple in operation.
- Adopt two steel cables for equalization, force two carriages to move synchronously, and effectively prevent the vehicle from tilting.
- Lowest height of lifting pad is 110mm, good for repairing low chassis or low profile car.

1.3 Functions and Features

- The cable and oil pipe are fully concealed, with decent and elegant appearance.
- Designed based on the international standard, meeting the demand of the garage and workshop.

1.4 Technical Specifications

Noise:

Working noise: $\leq 75\text{dB}$ (A)

Power unit:

Working pressure: 18 MPa

Electrical parameters of the machine:

Motor:

Single phase: 220V/60Hz 2.2 kW

Basic parameters of the equipment:

Model	Rated load	Lifting height	Rising time	Descending time	Net weight	Passing width	Machine width	Machine height
TLT240SC (Symmetric installation)	4000 kg	1850 mm	$\leq 50\text{s}$	$\geq 20\text{s}$	690kg 1521 lb	2486 mm 97.9 in	3420 mm 134.6 in	3840 mm 151.2 in
TLT240SC (Asymmetric installation)	9000 lb	72.8 in		$\leq 40\text{s}$		2415 mm 95.1 in	3563mm 140.3 in	

TLT240SC: When top beam are assembled by interior and exterior beam, the width is adjustable, can be narrowed another 150mm (5.9") than the normal setup

TLT240SC: Optional Low Height set-up by 300mm (11.8") available. Special length Cables & Hose required. Refer to Parts List. Call Dealer for purchase details.

1.5 Environmental Requirement

Working temperature: $-5^{\circ}\text{C} \sim +40^{\circ}\text{C}$

Transport/storage temperature: $-5^{\circ}\text{C} \sim +40^{\circ}\text{C}$

Relative humidity: Temperature $+30^{\circ}\text{C}$, Relative humidity 80%

Height above sea level: No more than 2000m

2. Lift Structure

2.1 Lift structures are shown as below:

Model	Description
TLT240SC clear-floor 2-post lift	4.0T clear-floor 2-post lift (Fig.1、 Fig.2、 Fig.3)

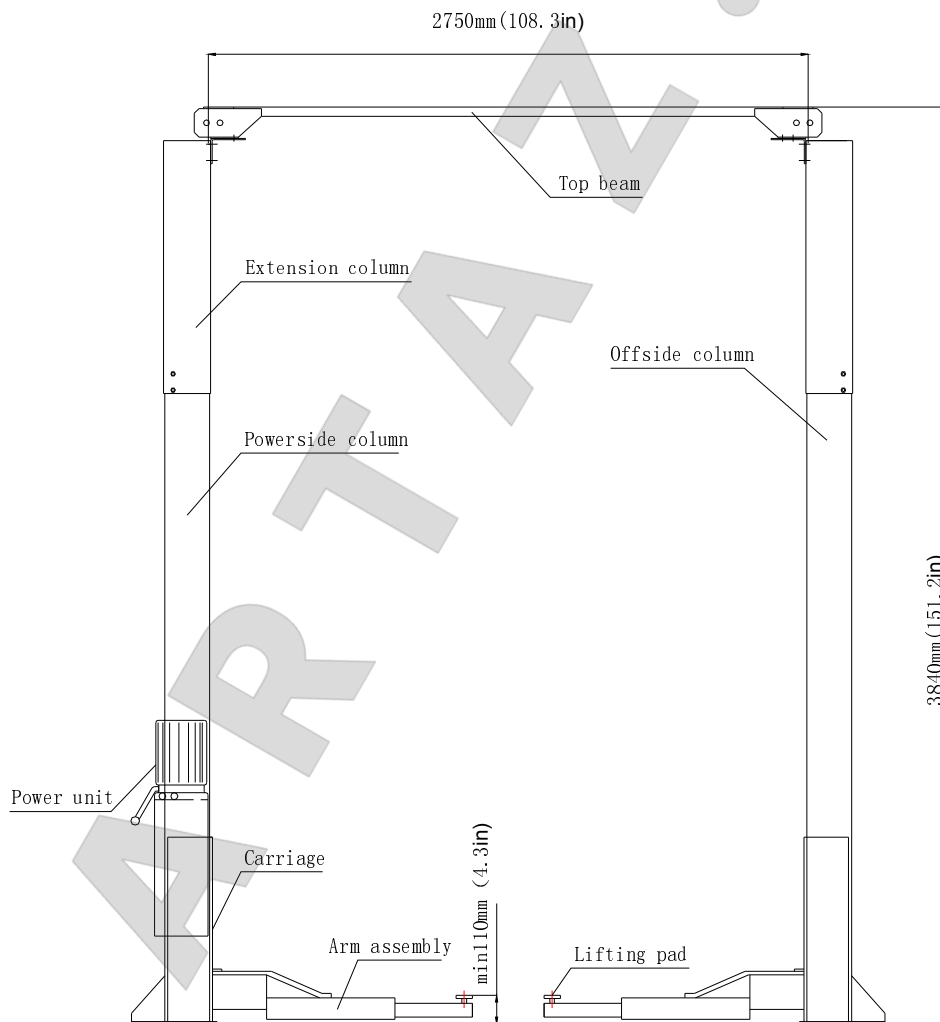

Fig.1

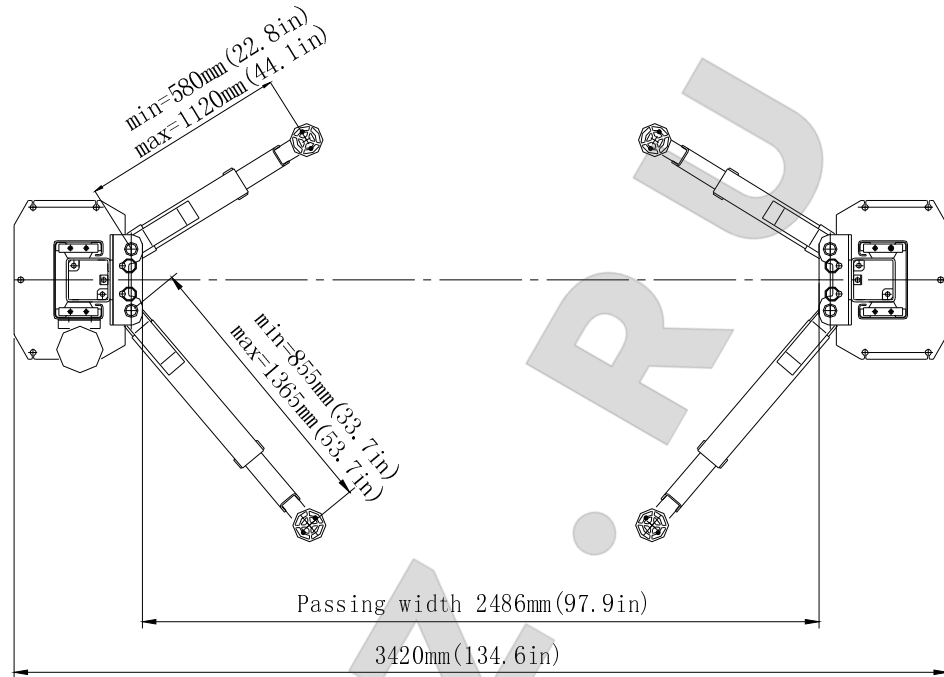

Fig.2

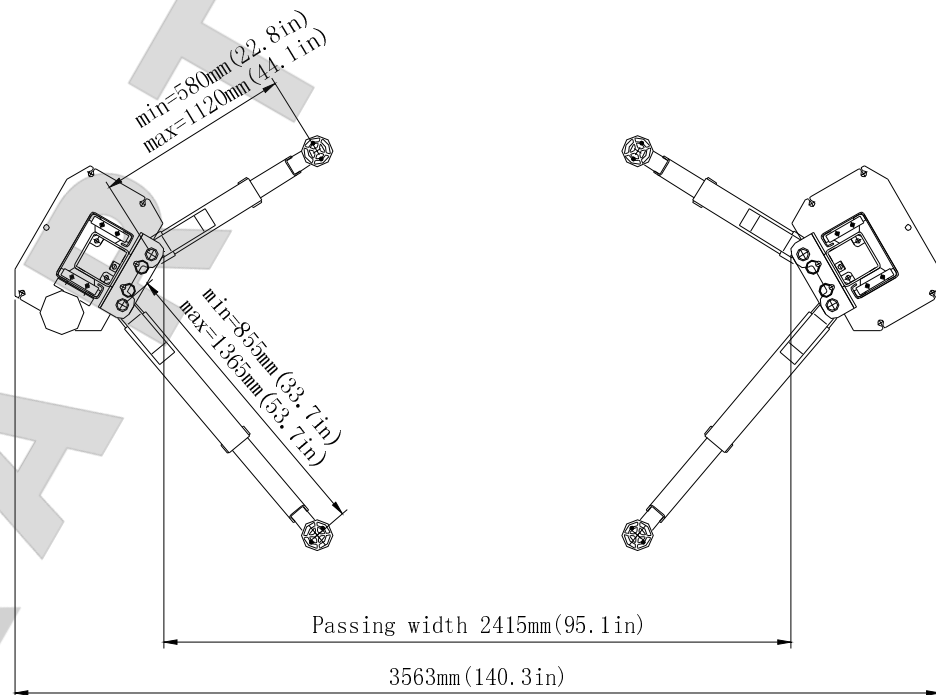

Fig.3

2.2 Main structure principles:

- Lifting mechanism: Each column is installed with a hydraulic cylinder, when hydraulic oil is pressed from power pack into the lower chamber of main cylinder, piston rod moves upwards to drive the upward movement of carriage through leaf chain.
- Load supporting mechanism: When vehicle drives into the working area, adjust the angle and telescopic length of arms to make lifting pads at an effective load supporting position that contact with vehicle, and then adjust the lower screw's height of lifting pad to make it applicable for vehicles with different chassis.
- Balance mechanism: In order to keep machine balanced during lifting and lowering, two carriages are interconnected and forced to move synchronously by two wire ropes. If the right and left carriages and arms are not at the same level, adjust the end nut of wire rope and pull wire ropes tight to make arms leveled.
- Manual safety locking mechanism: the safety locking plates are installed on the two carriages and the toothed bar plate is welded on the internal wall of the column. During the lifting of the carriage, the safety locking plate goes up against on the toothed bar plate under the tension of spring. When the carriage stops, the safety locking plate opens and then is engaged in the toothed bar slot to ensure the carriage will not go down; when the lowering operation is required, just raise the carriage upward a little to loosen the safety locking plate from the toothed bar slot, and then manually pull the steel wire rope to let sliding plate lift up the safety locking plate so that the safety locking is released, the carriage can be lowered down. Because the manual safety locking device are installed on the two carriages, double safety protection is provided; therefore, to disengage the safety locking, the steel rope on the two carriages shall be respectively pulled. To prevent the vehicle from slipping off, the swing arm assembly employs positioning mechanism, makes the swing arm capable of automatic locking during operation.
- Safety lock scope: Safety lock mechanism is effective when the front end of carriage is between 450mm and 1850mm high above the ground.

3 Operation Descriptions

3.1 Precautions for vehicle repair work

- Different vehicles have different center of gravity positions. First understand the position of center of gravity, and when the vehicle enters into the lift, make its center of gravity close to the plane formed by two columns. Adjust the swing arm, and make the lifting pad support onto the lifting point of the vehicle.
- For vehicle lift with top beam, pay attention to the car roof position observation in order to avoid accident during lifting.
- Carefully read the warning symbol.
- The hydraulic valves have been adjusted before ex-factory, and the user can't make self-adjustment, otherwise it will be responsible for all the consequences generated.
- Based on the production, some specifications in the instruction manual are subject to change without notice.

3.2 Preparation before Operation

- Lubricate contact surface of the carriage with general-purpose lithium grease (GB7324-87). All sliding surface should be coated evenly from the top to bottom.
- Fill hydraulic oil N32 or N46 to the oil reservoir of the power unit.

3.3 Inspection before operation

- Check to see if the motor power is installed properly.
- Check to see if all the connection bolts are fastened.



Note: Don't operate the lift with damaged cables or damaged and missing part, until it is inspected and repaired by the professionals.

3.4 Lifting the Vehicle

- Keep work area clean; don't operate the lift in cluttered work area.
- Lower the carriage to the lowest position.
- Reduce the swing arm to the minimum length.
- Swing the arm along the route of the vehicle.
- Move the vehicle to the location between the two columns
- Swing the arm and put the lifting pad below the recommended lifting point, and adjust the height of lifting pad to touch lifting point of vehicle
- Press the UP button on the electric control box, slowly lift the vehicle to ensure the load balance, and then raise the lift to the required height.
- Release the UP button.
- Push the lowering handle to engage the safety lock of carriage. At this time, the vehicle can be repaired.

**Note:**

- ✧ **Before operation, the safety locking devices must be inspected. 1) The gear blocks of the arm end must engage the gear block of the restraint shaft. 2) No broken strand in the steel cable. 3) No deformation in the arm pad.**
- ✧ **When lifting the vehicle, all the swing arms must be used.**
- ✧ **Before lifting the vehicle, check all the hydraulic hose and fittings for oil leakage. In case of leakage, please don't use the lift. Remove the fitting with leakage and re-seal. Re-install the fitting and check if oil leakage still exists.**
- ✧ **After the vehicle is lifted, when adding or removing any major heavy object, use jack stand to maintain the balance of the vehicle.**

3.5 Lowering the Vehicle

- Clean the work area before lowering the vehicle.
- First press the start button to raise the vehicle a little, and then pull two steel ropes on two carriages to disengage the safety lock.
- Press the lowering handle to lower the vehicle.
- Lower the vehicle till the swing arm down to the bottom and the lifting pads leave the vehicle chassis, and then release the lowering handle.
- The swing arms under the vehicle must be fully shrunk



Note: When the lift doesn't work, you must switch off the power.

4 Hydraulic and Electrical System of the Equipment

4.1 Hydraulic System of the Lift

Diagram of the hydraulic system of clear-floor 2-post lift

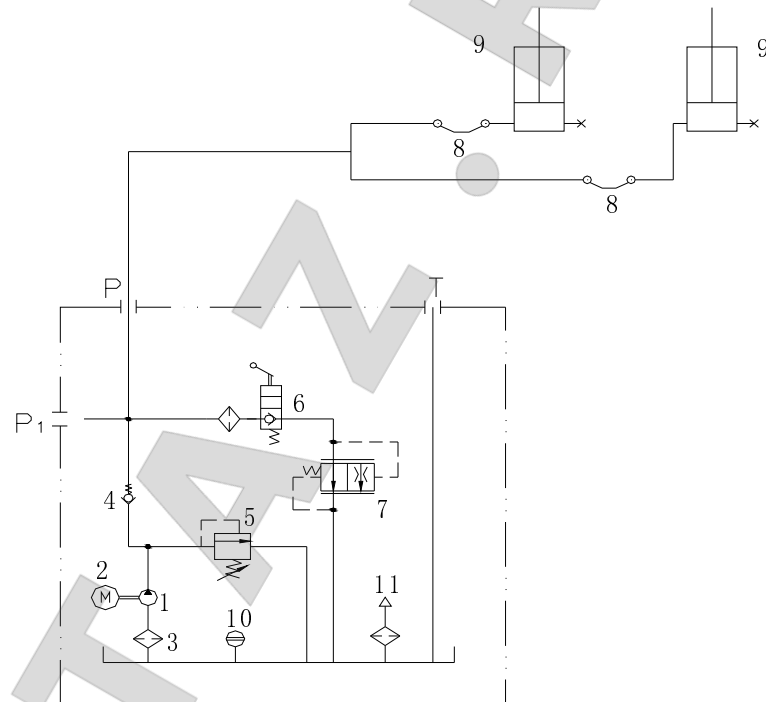

Fig 4

- 1- Gear pump, 2- Motor, 3- Oil filter, 4- Check-valve, 5- Safety valve, 6- Lowering handle valve,
 7- Servo flow-control valve, 8- Hose, 9- Hydraulic cylinder, 10- Level gauge, 11- Air filter

The working principle of the hydraulic system is as follows:

As shown in Fig.4, when the start button is pressed, the motor 2 is activated, driving the oil pump 1, sucking the hydraulic oil from the oil tank into the oil cylinder 9, forcing the piston rod move. At this time, the safety valve 5 is closed. (The max working pressure is already adjusted before ex-factory. The safety valve can ensure the capacity of the rated load, but when the pressure in the system

exceeds the limit, automatic overflow will happen inside safety valve to protect the hydraulic system). Release the start button to stop the oil supply and the lifting will stop. For lowering, first start Motor 2 to raise vehicle a little, pull the steel ropes on two carriages to release the safety lock mechanism, then press the lowering handle, the valve 6 is actuated, the hydraulic oil flows back and the lift starts lowering.

4.2 Electrical System of the Lift

Diagram of electrical system for single phase motor

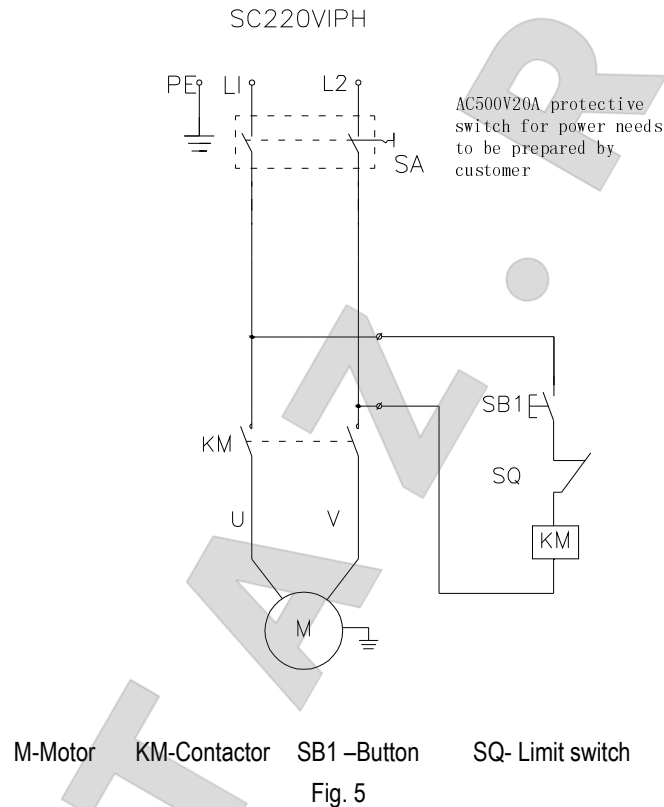

The electrical working principle is as follows:

Press the start button (SB1), and the contactor (KM) will be powered; motor (M) is energized to drive the gear pump supplying oil to push the carriage upward; release the start button, and the contactor (KM) is open, then the motor (M)

will lose the power, so the carriage will stop rising. As for the clear-floor lift, if the vehicle is lifted up near the top and contacts the limit switch on the top beam, the contactor (KM) will open, then the motor (M) will lose the power, so that the carriage stops lifting to avoid hitting the top.

5 Solutions to FAQ

Symptom	Reason	Solution
Motor does not work	<ul style="list-style-type: none"> ◆ Check the circuit breaker or thermal relay for tripping ◆ Check the voltage to the motor ◆ Check the electrical wiring ◆ Limit switch is failed ◆ Motor wire is burnt 	<ul style="list-style-type: none"> ◆ Close the switch of circuit breaker or press the blue reset key of thermal relay ◆ Supply correct voltage for motor ◆ Correctly wiring as electrical system diagram ◆ Replace the limit switch ◆ Replace the motor
Motor is running, but the lift can't be raised.	<ul style="list-style-type: none"> ◆ Motor rotation reversed ◆ Lowering valve body open. ◆ Hydraulic pump sucks the air ◆ Suction tube is separate from the hydraulic pump ◆ Low oil level 	<ul style="list-style-type: none"> ◆ Change the motor rotating direction through changing wire connection. ◆ Repair or replace the lowering valve body ◆ Fasten all the suction pipe fittings ◆ Replace the suction tube ◆ Add the oil into the oil tank
Motor is running, the lift can be raised without load, but the vehicle can't be raised	<ul style="list-style-type: none"> ◆ Motor is running under low voltage ◆ Impurities inside the lowering valve body ◆ Regulation pressure of safety valve is incorrect ◆ Lift is overloaded 	<ul style="list-style-type: none"> ◆ Supply correct voltage to the motor ◆ Remove impurities from the lowering valve body. ◆ Adjust the safety valve ◆ Check the weight of the vehicle
The lift is lowering slowly without pressing the lowering handle	<ul style="list-style-type: none"> ◆ Impurities on the lowering valve body. ◆ External oil leakage 	<ul style="list-style-type: none"> ◆ Clean the solenoid valve body ◆ Repair the external leakage
The lifting speed is slow or oil flows out of the oil fill cap	<ul style="list-style-type: none"> ◆ Air and oil is mixed ◆ Air and oil suction are mixed ◆ Oil return pipe is loosened 	<ul style="list-style-type: none"> ◆ Replace the hydraulic oil ◆ Fasten all the suction pipe fittings ◆ Re-install the oil return pipe
The lift can't rise horizontally	<ul style="list-style-type: none"> ◆ Balance cable is not adjusted properly ◆ The lift is installed on the slop floor 	<ul style="list-style-type: none"> ◆ Adjust the balance cable to the proper tension ◆ Shimming the columns to level the lift (no more than 5mm), if exceeding 5mm, pour new concrete floor and make it leveled. Refer to installation description.
Anchor bolt is not fastened	<ul style="list-style-type: none"> ◆ Hole is drilled too big ◆ Concrete floor thickness or fastening force is insufficient . 	<ul style="list-style-type: none"> ◆ Pour the fast curing concrete into the big hole and reinstall the anchor bolt , or use new drill to drill the hole for re-positioning the lift ◆ Cut open the old concrete and make new concrete slab for the lift. Refer to installation description.

6. Repair and Maintenance

Keep clean

- This unit should be cleaned with dry cloth frequently to keep it clean. Before cleaning, first switch off the power to ensure the safety.
- The working environment of this unit should be clean. In case of dust in the working environment, it will speed up the parts wearing and shorten the service life of the lift.

Every day:

- Before the operation, carefully check the safety mechanism of the lift to ensure the electromagnet suction and release action is proper, and the safety plate is in good condition. When finding any abnormal situation, make adjustment, repair or replacement immediately.
- Check to see if the steel cable connection is proper, and if the tension is at the optimum status.
- Check to see if the connection between hydraulic cylinder and carriage is proper, if the connecting nut between the steel chain and carriage is loose or falling. Refer to Fig.6

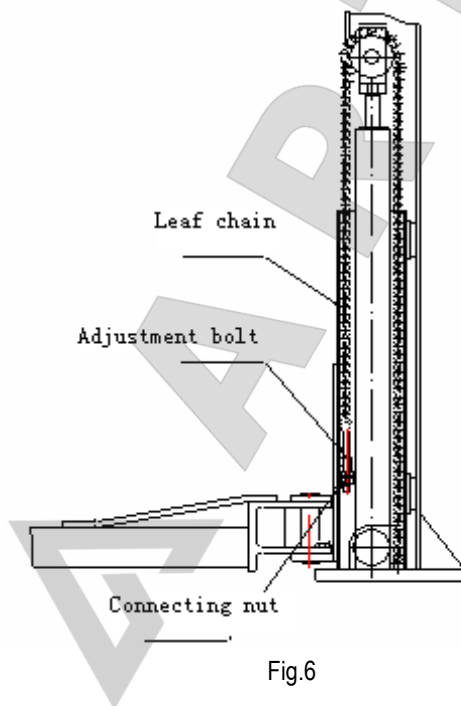

Every month:

- Retighten the anchor bolts.
- Lubricate chains/cables.
- Check all the chain connectors, bolts and pins to ensure correct installation
- Check all the hydraulic lines for wearing
- Check to see if the carriage and the inner side of the column are properly lubricated. Use high-quality heavy lubrication grease (lithium based lubrication grease GB7324-87).



Note: All the anchor bolts should be tightened completely. If any screw doesn't function for some reason, the lift can not be used until the bolt is replaced

Every six months:

- Check all the movable parts for possible wearing, interference or damage.
- Check the lubrication of all the pulleys. If the pulley has dragging during the lifting and lowering, add appropriate lubricant to the wheel axle.
- When necessary, check and adjust the balancing tension to ensure the horizontal lifting and lowering.
- Check the verticality of the column.



Note: The inner corner of each column should be lubricated with lubricant, to minimize the roller friction and ensure the smooth and even lifting.

Maintenance of hydraulic system:

- Clean and oil change
In the six months after initial use of this unit, clean the hydraulic oil tank and replace the oil, later clean the hydraulic system once a year, and replace the oil. See Fig. 7
- Replace the seal
After this unit is put into operation for certain period, if finding the oil leakage, carefully check it; if the leakage is due to the wearing of sealing materials, immediately replace the worn one based on the original spec. See Fig. 7

Diagram of hydraulic line of clear-floor 2-post lift

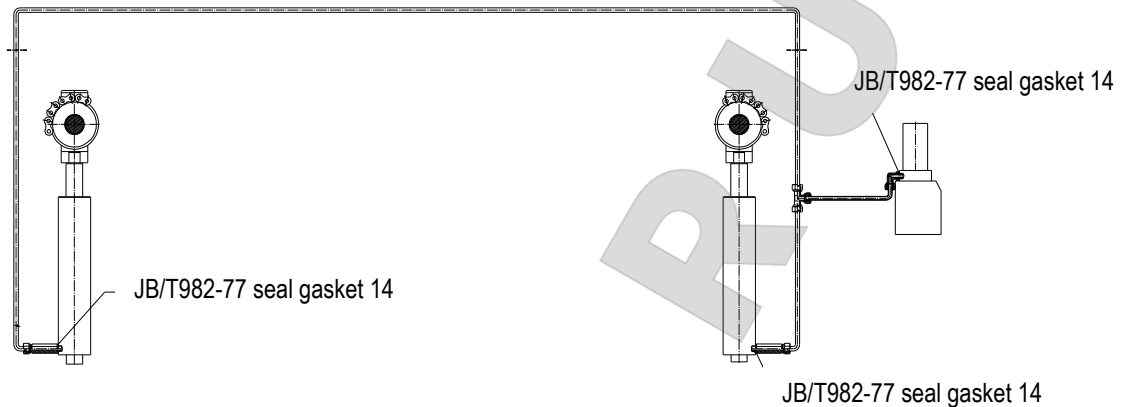

7. Storage and Scrap

7.1 Storage

When the equipment requires long-time storage:

- Disconnect the power supply
- Lubricate all the parts requiring lubrication: mobile contact surface of the carriage, etc.
- Empty all the oil/liquid storage units
- Put the plastic cover over the equipment for dust

7.2 Scrap

When the equipment service life is expired and can no longer be used, disconnect the power supply, and properly dispose of as per relevant local regulations.

8. Tools for Installation and Adjustment

To ensure proper installation and adjustment, please prepare the following tools:

Tool	Model
Leveling instrument	Carpentry type
Chalk line	Min 4.5m
Hammer	1.5kg
Medium crescent wrench	40mm
Open-end wrench set	11mm-23mm
Ratchet socket set	
Flat Screw driver	150mm
Rotary hammer drill	20mm
Concrete drill-bit	∅ 19mm

9. Unpacking

Open the packing box: remove the packing materials and inspect the lift for any sign of shipment damage. Check by packing list to see if the main parts and accessories are complete.

Keep the packing materials away from the children to avoid danger: if the packing materials cause the pollution, they shall be treated properly.

10. Installation

10.1 Important notice

- The wrong installation will cause the lift damage or personal injury. The manufacturer will not undertake any responsibilities for any damage caused due to incorrect installation and usage of this equipment, whether directly or indirectly.
- The correct installation location shall be "horizontal" floor to ensure the horizontal lifting. The slightly slope floor can be corrected by proper shimming. Any big slope will affect the height of the lifting pad when at the bottom or the horizontal lifting. If the floor is of questionable slope, consider a visual inspection, or pour a new horizontal concrete slab if possible. In short, under the optimum horizontal lifting status, the level of the lifting relies on the level of the floor where it is installed. Don't expect to compensate for the serious slope.
- Don't install the lift on any asphalt surface or any surface other than concrete. The lift must be installed on concrete floor conforming to the minimum requirement showed in this manual. Don't install the lift on the concrete with seams or crack and defect. Please check together with the architect.
- Without the written approval of the architect, don't install the lift on a second floor with basement.
- Overhead obstruction: The lift installation area can't have any overhead obstruction, such as heater, building support, electrical pipe, etc.
- Concrete drilling test: The installation personnel can

test the concrete thickness at each site by drilling test. If several lifts are installed at one place, it is preferred to make drilling test in each site.

- Power supply: Get ready the power supply before the installation. All the electric wiring and connecting should be performed by a certified electrician.

10.2 Installation Procedure

10.2.1 Selecting installation site

Selecting installation site based on the following conditions:

- Lift can only be installed on concrete slab, which must have a minimum thickness of 108mm (4-1/4") and should be aged 7days at least.
- The concrete slab shall have reinforcement by steel bar.
- The concrete slab must be leveled.
- If the thickness of the whole ground concrete is greater than 108mm (4-1/4") , the lift can be installed directly
- Check the possible obstruction, e.g. low ceiling, top pipeline, working area, passage, exit, etc.
- The front and back of the lift should be reserved with sufficient space to accommodate all the vehicles (Fig. 8).(evaluating from the center line ,each edge should be about 4m)

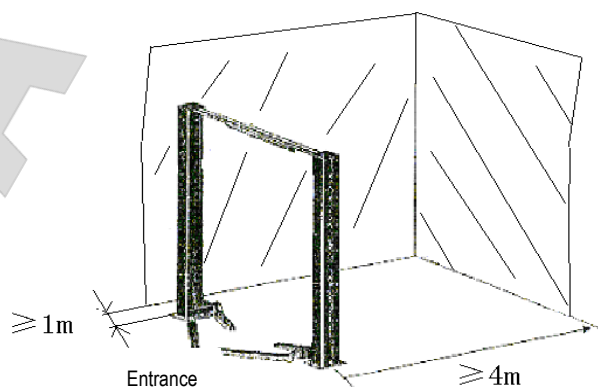

Fig. 8

10.2.2 Base plate layout

TLT240SC symmetric installation is shown in Fig. 9:

- With total width (A) as the basis, draw two parallel lines (#1 and #2) on the concrete slab, with the error within 3mm.
- Determine the power side column location on any

chalk line, and mark the total width (B) of the base plate. Mark the points 3 and 4.

- Starting from point 3, draw one diagonal line (C), forming a triangle. In this way, the vertical lines can determine the location of the two columns.

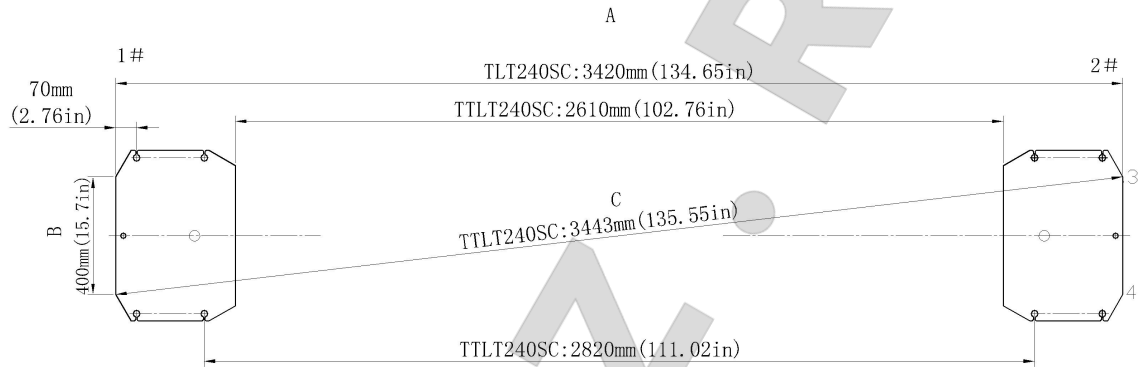

Fig.9

TLT240SC asymmetric installation is shown in Fig.10:

- With total width (A) as the basis, draw two parallel lines (#1 and #2) on the concrete slab, with the error within 3mm.
- Determine a point B at any point on chalk line #1,

based on point B, move down 131mm, then move right 228mm to get point C. Based on point B, draw #1's vertical line M with a length of A to get point D. Based on point C, draw line M's parallel line N with a length of L to get point E. With four points B,C,D,E, each post's position can be decided.

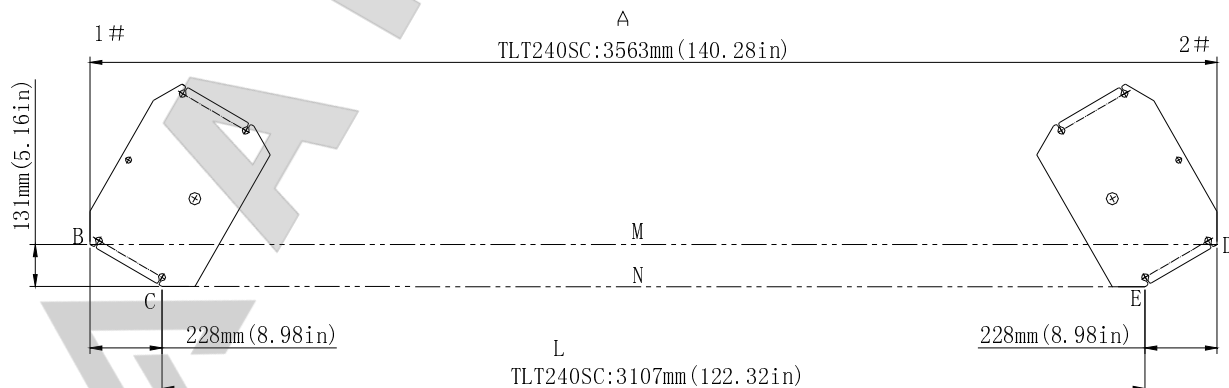

Fig.10

Note:

- **All the dimensions are based on the external border of the base plate.**
- **Ensure the overall error is controlled within 6mm. In this way, the difficulties in the final assembly, or early wear or non-alignment of the chain can be eliminated. The marking and layout is very important. If it is inaccurate, there will be problems during the final assembly and operation.**

10.2.3 Install the power side column

For clear-floor two post lift, first install extension column with column, then use lifting equipment to place power side column upper right to the location. Align the base plate of column with the chalk line layout. Guided by holes on the base plate of the column, used 5 concrete anchor bolts to fix it onto the ground. Drill and install anchor bolts at one time, during the drilling process, ensure no movement of the column. (Fig.11).

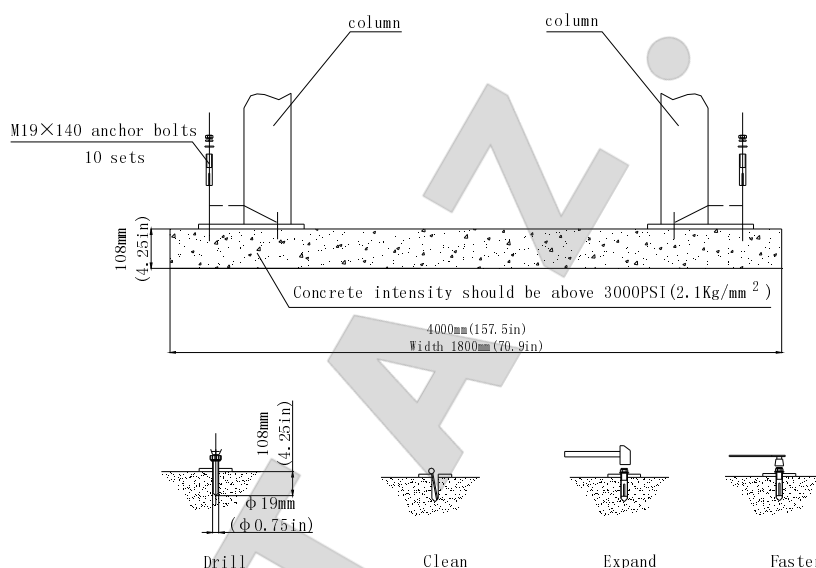

Fig.11

Note:

- ◆ **Use sharp $\Phi 19$ mm concrete drill-bit to drill the holes so as not to drill the hole too large. Use proper pneumatic tool to remove the dust from the hole. The depth of the hole is the same as that of the anchor bolt. Insert the anchor bolt and make the washers lean against the base of the column.**
- ◆ **Only use torque wrench instead of impact tools to fasten anchor bolts.**
- ◆ **Insert proper steel shim under the base seat of column to plumb the column.**



Note: The thickness of shims shouldn't exceed 5mm.

To get the correct and safety installation, please follow the following installation steps.

- Wear the safety goggles
- Use hard alloy drill-bit.
- Don't use the drill-bit with wearing exceeding the tolerance.
- The drill and concrete surface should be kept perpendicular.
- Let the drill work itself. Don't apply the extra force, and don't ream the hole or allow the drill to wobble.
- The drilling depth of hole is based on the length of

anchor bolt .The distance from the bolt head to the concrete floor should be more than twice of the bolt diameter.

- Remove the dust from the hole.

- Gently tap the bolt into the hole till the washer rests against the base plate of column.
- Fasten bolts

10.2.4 Install the top beam

ASYMMETRIC PULLEY INSTALLATION

Use the 4 pulleys (sheaves) located in the parts packaging combined with the parts in the packet marked "Asymmetric Installation" to install the pulleys for an Asymmetric configuration. Below is what is contained in the asymmetric parts packet.

No.	Name and Specs	Part Number	Qty.	picture
1	Asymmetric axle	103200966	4	
2	Bushing II	103203325	2	
3	Bushing I	103203324	2	
4	Returning ring 25	103050035	8	

Asymmetric Pulley Configurations Continued...

The photo below illustrated the proper alignment and placement of the pulleys into the overhead beam. Note the outer pulley is positioned on the overhead beam in the outer most axle holes and that it is closest to the front of the lift. The inner pulley is positioned in the inner most axles holes and is mounted toward the rearward area of the lift .when installing the opposite set of pulleys they must correspond exactly as the first set of pulleys that you installed.

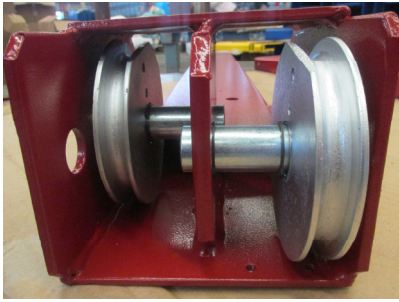

Note: inner pulley is facing to rear of the lift

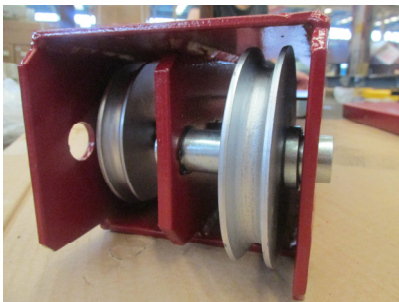

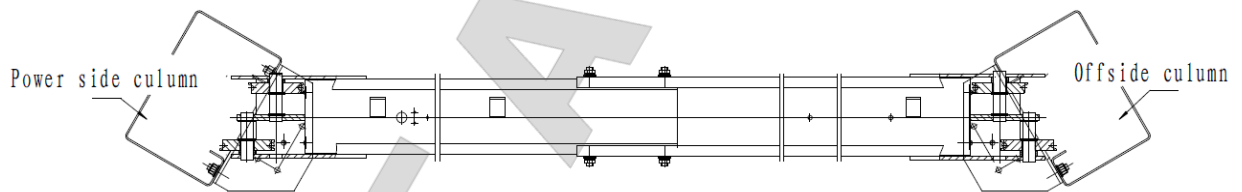

Note: Outer pulley is facing to front of the lift



Asymmetric top beam as shown:

SYMETRIC PULLEY INSTALLTION

Use the 4 pulleys (sheaves) located in the parts packaging combined with the parts in the packet marked "Symmetric Installation" to install the pulleys for a Symmetric configuration. Below is what is contained in the symmetric parts packet.

No.	Name and Specs	Part Number	Qty.	picture
1	symmetric axle	103200967	2	
2	Bushing II	103203325	2	

3	Bushing I	103203324	2	
4	Cotter Pin 5 × 40	103060349	4	
5	Returning ring 25	103050035	4	

Symmetric Pulley installation Continued...

The photos below illustrate the proper alignment and placement of the pulleys (sheaves) into the overhead beam. Note that both pulleys are positioned on the overhead beam sharing a common axle and the axle is positioned in the inner most axle holes and that is closest to inner most area of the overhead beam. Install both sets of pulleys on each end of the over beam to exactly match each other.

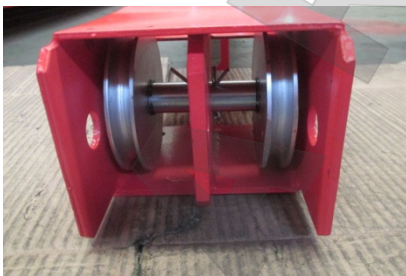

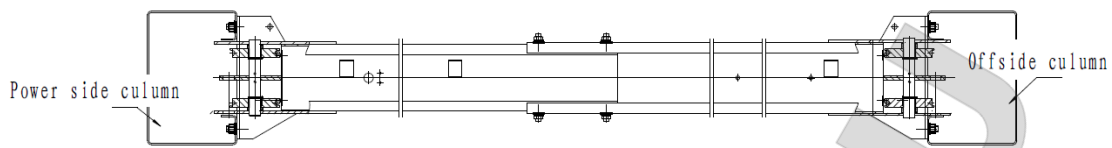

symmetric top beam as shown:

Position the offside column at the designated chalk location. Lift the top beam to its high position, and use four M12 bolts, washers and lock nuts to fix it with the columns (as shown in Fig.12). When installing the top beam, ensure the above micro switch support bracket adjacent to the power side column. In Fig12:The symmetric top pulleys are to be

installed at position 1、1", asymmetric top pulleys are to be installed at position 2、2".



Note:

✧ **Since the offside column is not fixed to the ground, you must operate carefully to avoid the falling of the column.**

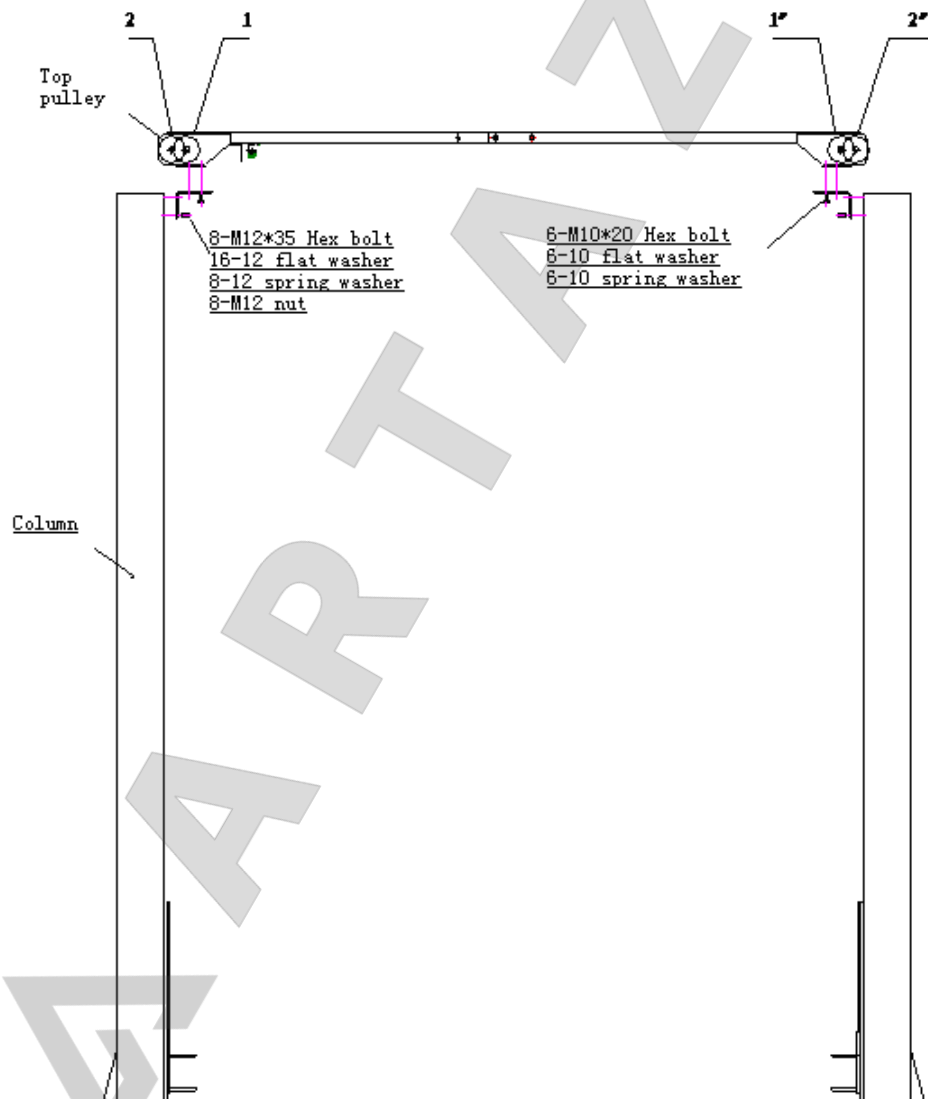

Fig. 12

10.2.5 Install the offside column

Install the offside column as the procedures in 10.2.3.

10.2.6 Install and adjust the balancing steel cables

- Raise the two carriages to the safety locking position; make sure the two carriages are of the same height from ground. for TLT240SC models, route the steel

cables as Fig. 13 shows .

- Adjust the tension of cables through the adjustment nuts on each end of steel cable. The steel cables should be tight in equal tension. Each steel cable should be ensured in the pulley when adjusting tightly, otherwise the steel cable will be damaged.

⚠ Note: Before operating the lift, re-check the balancing steel cables and ensure they are not crossing or wrongly installed. Ensure the steel cables still in the pulley.

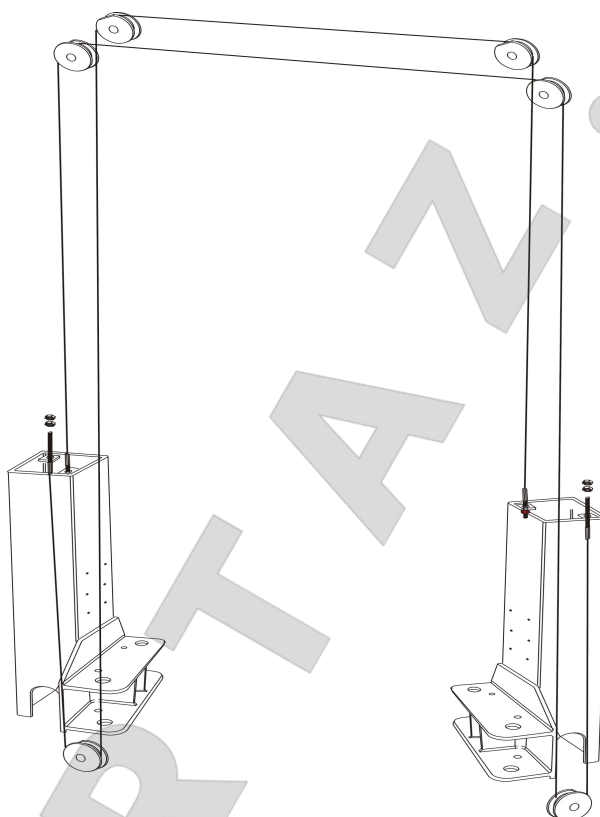

Fig.13

✧ **The two steel cables shall be adjusted to certain uniform tension to ensure the two carriages are moving synchronously.**

10.2.7 Install the power unit and hydraulic lines

- Use two M10 bolts and washers to fix the power unit (as shown in Fig. 14). for TLT240SC models, install the hydraulic line as shown in Fig.14 and tighten all the fittings to prevent oil leakage.
- Fill the reservoir with hydraulic oil (oil capacity of 10L).

Operate carefully to avoid dust and other pollutants mixed with the hydraulic oil.

⚠ Note:

- ◆ Clean the impurities in the hydraulic line and remove the protective plug from the hydraulic cylinder.
- ◆ When the hydraulic hose installation needs to go through the column, ensure the hydraulic hose won't touch any movable parts inside the column
- ◆ During the installation, rubber cushions must be added between the hydraulic station and the installation plate

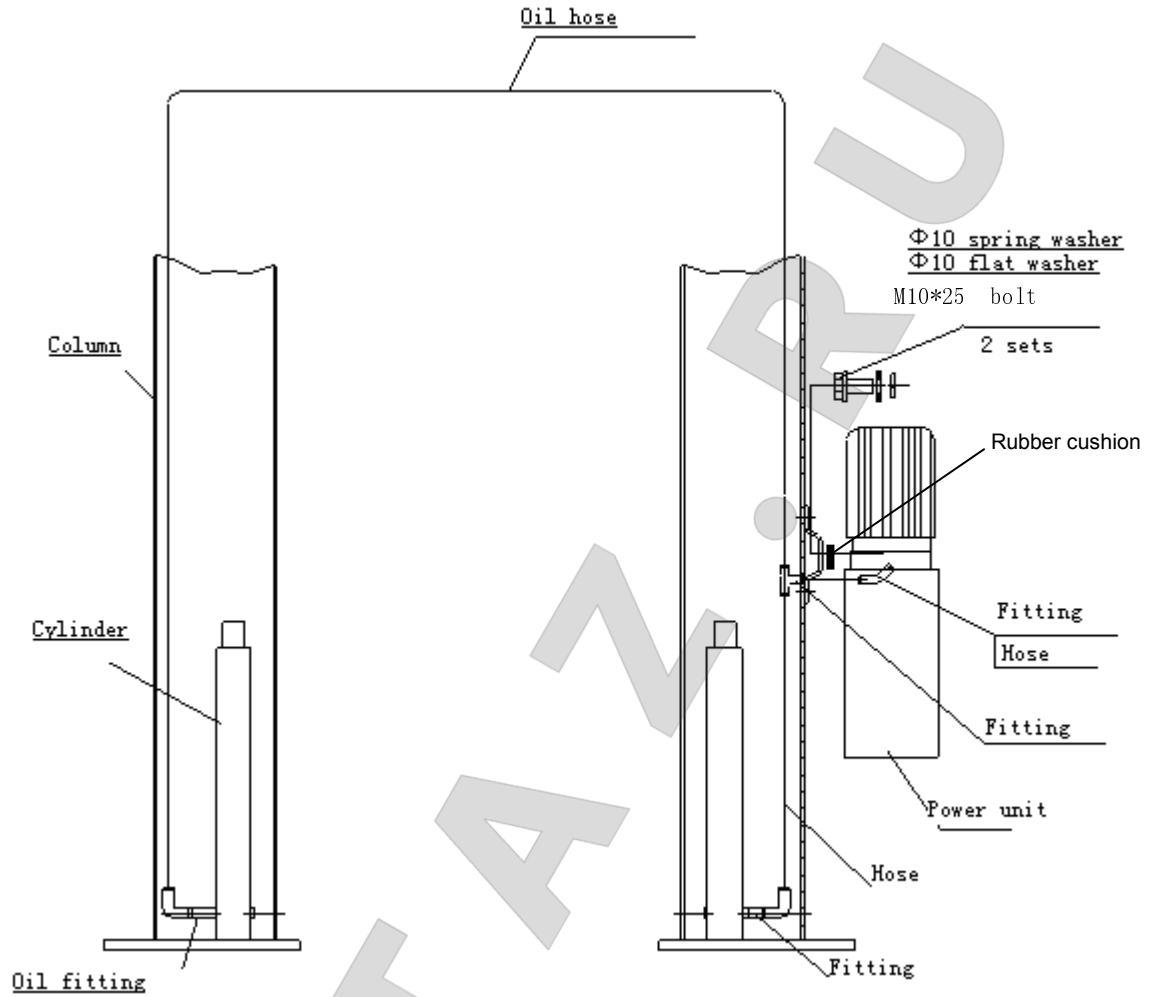

Fig. 14

10.2.8 Install the swing arm

Install the swing arm as shown in Fig.15



Note:

Before use, check if the positioning gear mechanism at the end of arm fits, adjust the screws of fixed semi-gear for its fitness.

During the installation, lubricate the moving parts of swing arm and carriage if accessory, so that the swing arm can move freely.

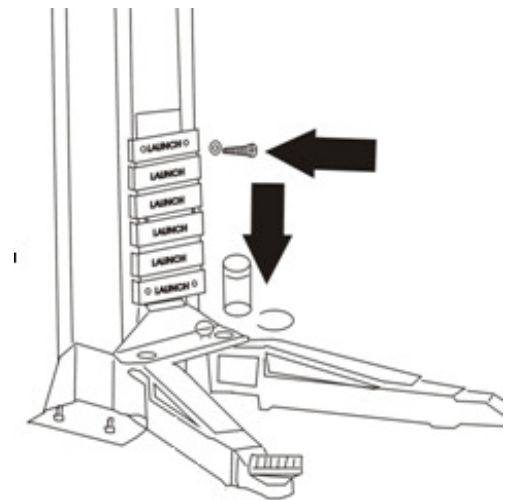

Fig.15



11. Lift Adjustment

11.1 Preparation before the adjustment

- Lubricate contact surface of the carriage and corners of column with general-purpose lithium grease. All sliding surface should be coated evenly from top to bottom.
- Fill hydraulic oil N32 or N46 to the oil reservoir of the power unit.

11.2 Adjustment procedure

- Check to see if the power supply is installed properly.
- Check for the tightness of all the connecting bolts.
- Press the start button on the motor, and the carriage rises; stop pressing the button, and then the carriage will stop. In order to lower the carriage, first pull the steel rope for releasing safety locks on the two carriages one time for each. In case of failure to pull the wire, re-pull after raising carriage a little. Press the lowering handle on the power unit and the carriage will be lowered; stop pressing the handle, then the carriage will stop. In case of vehicle repairing, when the vehicle is lifted up to the required height, first press the oil release handle to actuate the mechanical safety lock in order to ensure the safety operation.
- The hydraulic system may contain air due to new installation, to bleed the air, repeat the lifting and lowering for several times
- The adjustment is completed



12. List of the Lift components

This list is only used as the information for the maintenance and repair. Our company will not be liable for other uses.

In case of any damage parts, ask distributor for parts according to the part numbers described in detail

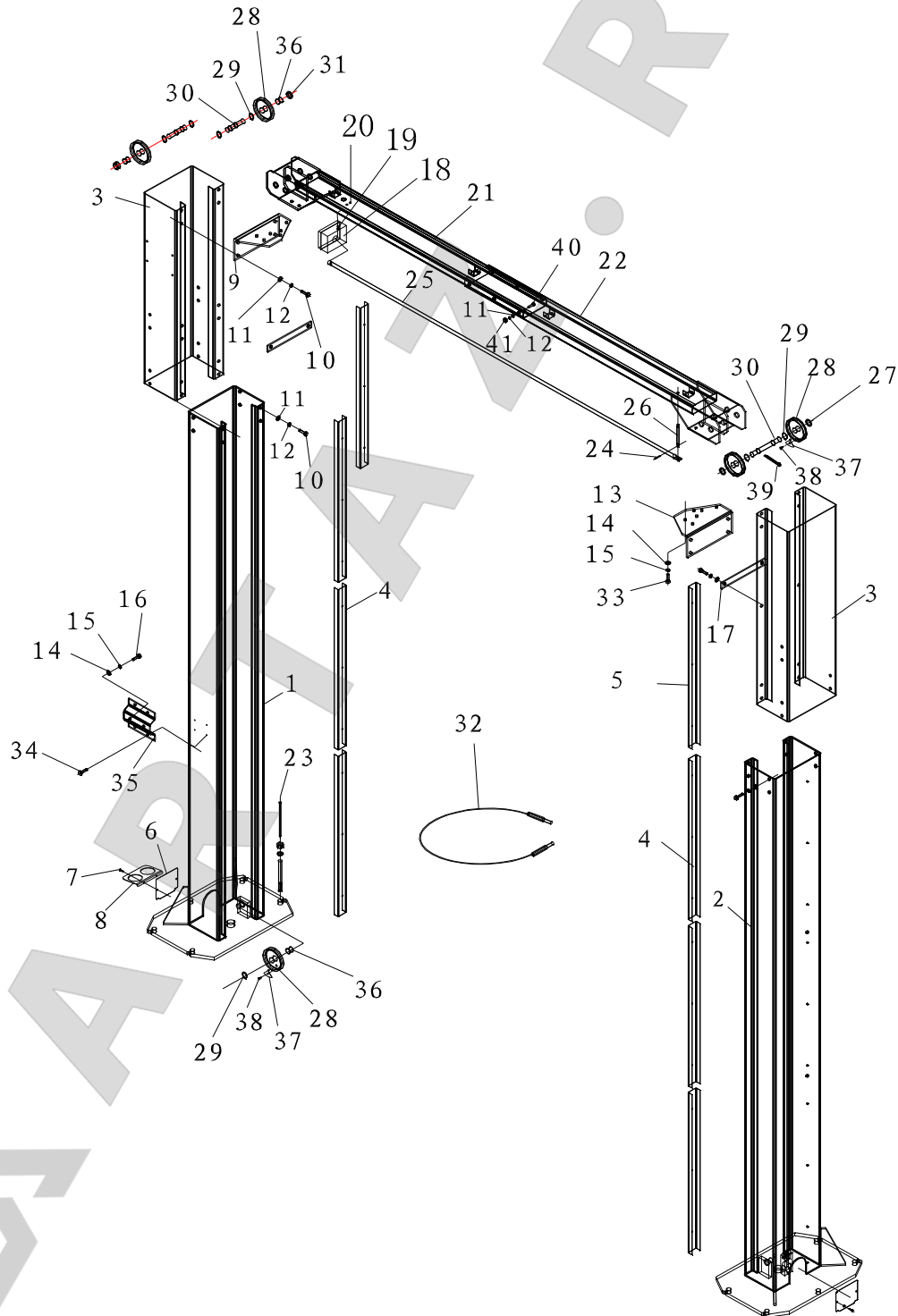

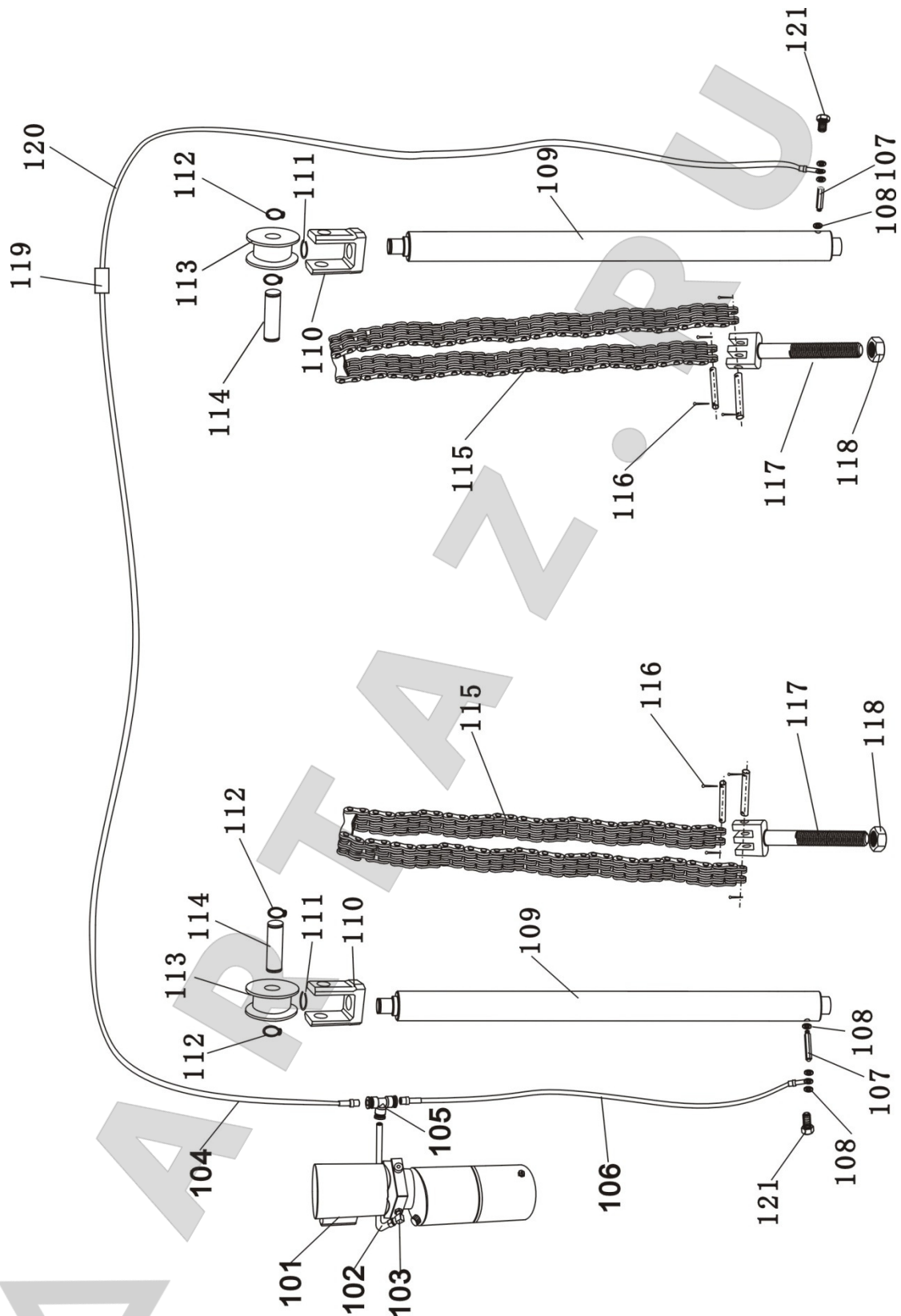

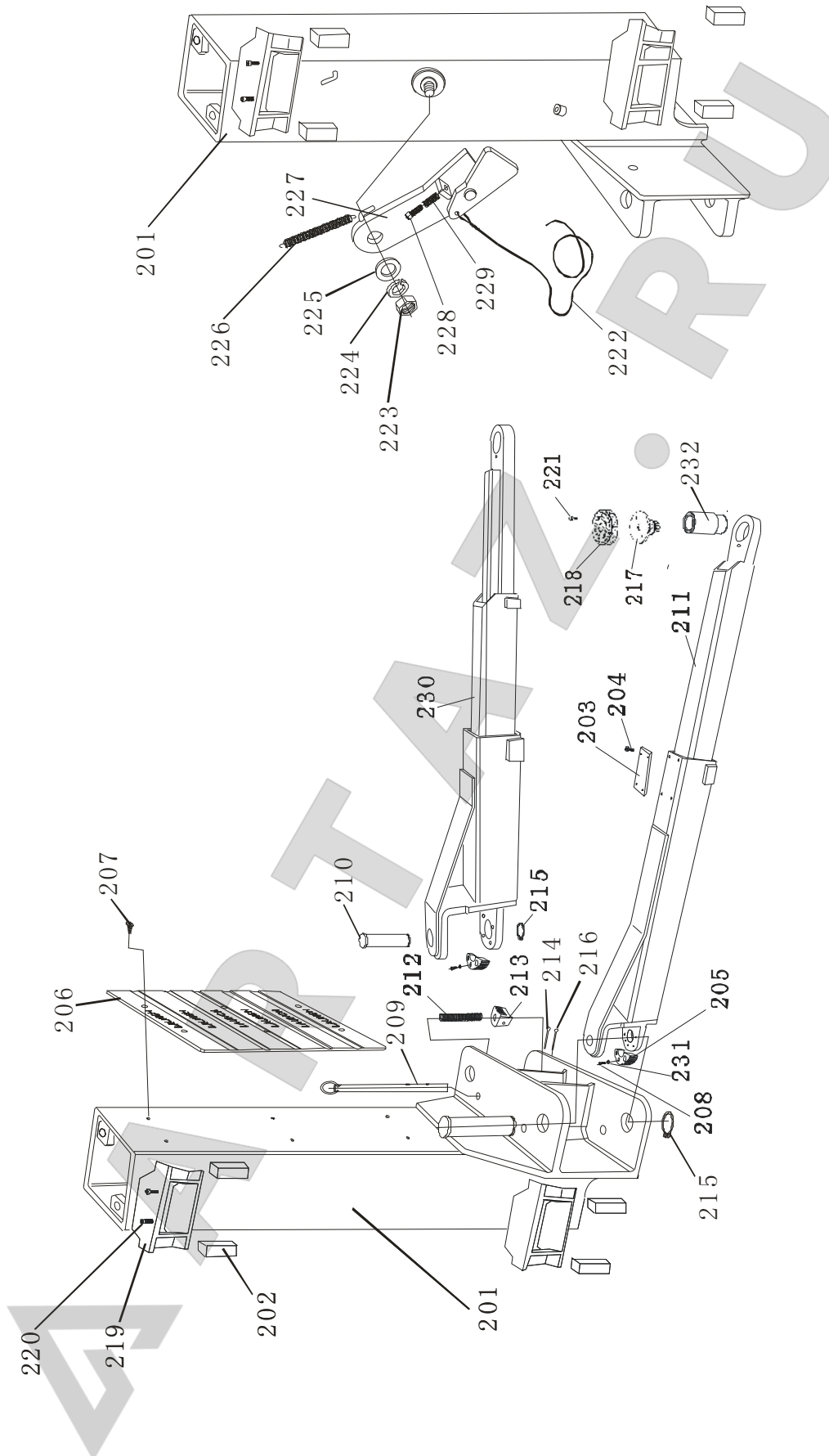



No.	Code	Name
1	201025104	TLT240SC Power side column
2	201025105	TLT240SC Offside column
3	201025112	TLT240SC Extension column
4	201025073	Protective cover inside the column
5	201025074	Protective cover for extension column
6	201011236	Bottom cover of column
7	103010498	Screw M5×8
8	201011242	Long sleeve shelf
9	201025066	Connecting bracket I
10	103020104	Bolt M12×35
11	103040110	Flat washer 12
12	103040044	Spring washer 12
13	201025067	Connecting bracket II
14	103040123	Flat washer 10
15	103040122	Spring washer 10
16	103020038	Bolt M10×25
17	201011176	Reinforced plate
18	108040166	Top limit assembly
19	103010432	Screw M5×12
20	103030018	Nut M5
21	201025579	Inner top beam
22	201025070	Outer top beam
23	103020117	Anchor bolt M19×140
24	103060342	Pin 3X26
25	103250270	Long rod
26	103203327	Long rod axle
27	103203325	Bushing II
28	103203017	Pulley
29	103050035	Returning ring 25
30	103200967	Symmetric axle
	103200966	Asymmetric axle
31	103203324	Bushing I
32	103260338	Steel cable
	103260374	Cable L=9996 (low-grade installation)
33	103020120	Bolt M10×20
34	103020190	Screw M6×10
35	201025083	TLT240SC Bracket for power unit
36	103200699	Bushing 2520
37	103203019	Lateral positioning sheet
38	103020188	Bolt M5×10
39	103060349	Pin 5×40
40	103020126	Bolt M12×25





41	103030129	Nut M12
101	103990088	Power unit
102	104120136	HP Hose L=880
103	103100170	Fitting M14×1.5
104	104120096	HP Hose L=5370
	104120184	High pressure hose L=4770 (low-grade installation)
105	103100172	T-fitting
106	104120116	HP Hose L=950
107	103202198	Throttle joint
108	103040157	Seal gasket 14
109	103260129	Sub cylinder
110	103220054	Sheave seat
111	104060016	Returning ring 32
112	103050014	Returning ring 30
113	103201950	Sheave
	103260098	Bushing 3052
114	103200973	Sheave axle
115	103200939	Leaf chain
116	X103060340	Pin 2×26
117	103200938	Chain threaded end
118	103030131	Nut M16
119	103100198	Fitting
120	104120118	Offside column HP Hose
121	103020166	Connecting bolt
201	201021322	carriage
202	104990132	Sliding block
	103202958	Sliding block adjustment shim (for adjusting)
203	104130186	Rubber pad on swing arm
204	103010608	Screw M6×10
205	103201771	Semi-gear
206	104130192	Door rubber pad
207	103010539	Screw M8×12
208	103011102	Screw M10×25
209	103202184	Top rod assembly
210	103202280	Pin
211	201025120	Long arm
212	103201914	Spring
213	103201744	Gear block
214	103060376	Pin 5×32
215	103050030	Returning ring 40
216	103060355	Pin 3.2×30



217	103201444	Lifting pad assembly
218	104130211	Rubber pad
219	201025138	top board
220	103020215	Screw M10×25
221	103010402	Screw M8×16
222	201020500	Steel cable assembly
223	103030131	Nut M16
224	103040159	Spring washer 16
225	103040136	Flat washer 16
226	103110061	Spring
227	103202345	Safety block
228	103010471	Screw M8 × 40
229	103110060	Spring
230	201025122	Three stage arm
231	103040122	Spring washer 10
232	103200970	Long sleeve

13 Packaging

Appendix: Transportation Guide

- The packaging of each model would include: 1# Angle iron bracket packaging and 2# cardboard box packaging. Transportation guide is printed on packing.
- While using forklift to lift the 1# packaging, the fork arms must be of same distance from the center of the packaging and the distance between two fork arms should at least be 700mm. While using a forklift to pick up goods, the forks should get into the area below them as deep as possible. The goods should not be touched by fork tips or pushed by them. Product damages caused by collision or high piling should be avoided

Model	Name	1# Angle iron bracket packaging	2# Cardboard box packaging
		Size Length ×Width ×Height	Size Length ×Width ×Height
TLT240SC	4.0t clear-floor two post lift	2810mm×610mm×900mm	820mm×250mm×360mm

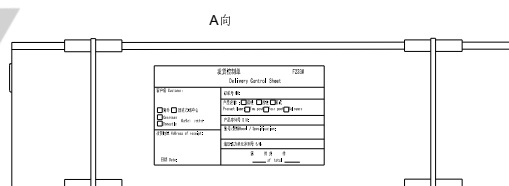
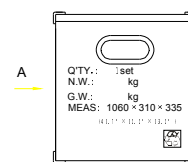
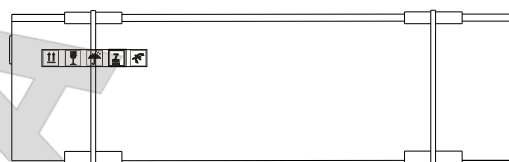
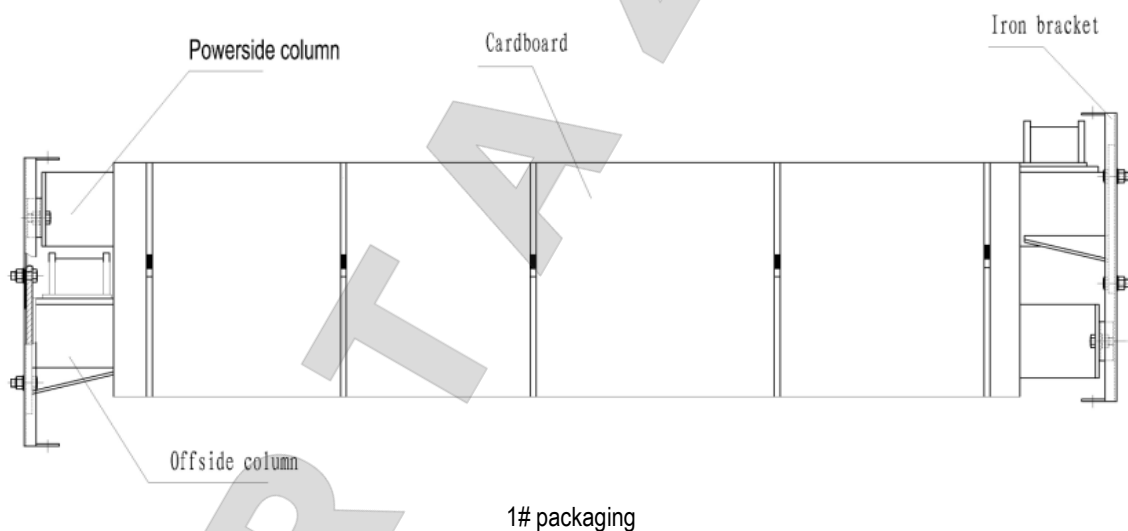

2# packaging

Grease and hydraulic oil for lift

2# lithium based lubrication grease

Item	Quality Index
Conical degree (1/10mm)	278
Dripping point/°C	185
Corrosion (T2 copper sheet, 100 °C, 24h)	No change for copper sheet
Copper mesh oil split (100°C, 22h) %	4
Evaporation (100°C, 22h) %	2
Oxidation stability (99°C, 100 h)	0.2
Anti-corrosion (52°C, 48)	Class 1
Impurity (microscope) / (pcs/cm ³)	
Above 10µm no more than	5000
Above 25µm no more than	3000
Above 75µm no more than	500
Above 125µm no more than	0
Similar viscosity (-15°C , 10s ⁻¹) ,/(Pa·s) no more than	800
Water spray loss (38°C, 1h) (%) no more than	8

N32 hydraulic oil (used for low ambient temperature)

Item	Quality Index
Kinematic viscosity 40°C	28.8~35
Pour point /°C no higher than	-15
Flash point /°C no lower than	175

N46 hydraulic oil (used for high ambient temperature)

Item	Quality Index
Kinematic viscosity 40°C	41.4~50.6
Pour point /°C no higher than	-9
Flash point /°C no lower than	185



LIMITED WARRANTY

Structural Warranty:

The following parts and structural components carry a five year warranty:

Columns Arms Uprights Swivel Pins
Legs Carriages Overhead Beam
Tracks Cross Rails Top Rail Beam

Limited One-Year Warranty:

Tuxedo Distributors, LLC (Tuxedo) offers a limited one-year warranty to the original purchaser of Lifts and Wheel Service equipment in the United States and Canada. Tuxedo will replace, without charge, any part found defective in materials or workmanship under normal use, for a period of one year after purchase. The purchaser is responsible for all shipping charges. This warranty does not apply to equipment that has been improperly installed or altered or that has not been operated or maintained according to specifications.

Other Limitations:

This warranty does not cover:

1. Parts needed for normal maintenance
2. Wear parts, including but not limited to cables, slider blocks, chains, rubber pads and pulleys
3. Replacement of lift and tire changer cylinders after the first 30 days. A seal kit and installation instructions will be sent for repairs thereafter.
4. On-site labor

Upon receipt, the customer must visually inspect the equipment for any potential freight damage before signing clear on the shipping receipt. Freight damage is not considered a warranty issue and therefore must be noted for any potential recovery with the shipping company.

The customer is required to notify Tuxedo of any missing parts within 72 hours. Timely notification must be received to be covered under warranty.

Tuxedo will replace any defective part under warranty at no charge as soon as such parts become available from the manufacturer. No guarantee is given as to the immediate availability of replacement parts.

Tuxedo reserves the right to make improvements and/or design changes to its lifts without any obligation to previously sold, assembled or fabricated equipment.

There is no other express warranty on the Tuxedo lifts and this warranty is exclusive of and in lieu of all other warranties, expressed or implied, including all warranties of merchantability and fitness for a particular purpose.

To the fullest extent allowed by law, Tuxedo shall not be liable for loss of use, cost of cover, lost profits, inconvenience, lost time, commercial loss or other incidental or consequential damages.

This Limited Warranty is granted to the original purchaser only and is not transferable or assignable. Some states do not allow exclusion or limitation of consequential damages or how long an implied warranty lasts, so the above limitations and exclusions may not apply. This warranty gives you specific legal rights and you may have other rights, which may vary from state to state.

1905 N Main St Suite C, Cleburne, TX 76033
Ph 817-558-9337/Fax 817-558-9740

