



# DA2002

# Instruction Manual



English





## Table of Contents

|   |           |
|---|-----------|
| <b>1. Summary</b>                         | <b>3</b>  |
| <b>2. Important Safety Instructions</b>   | <b>6</b>  |
| 2.1 First Installation                    | 8         |
| 2.2 Controls DL2002 Lathe                 | 12        |
| 2.3 Controls DU2010 Drive Unit            | 13        |
| <b>3. Preparation</b>                     | <b>16</b> |
| <b>4. Fitting Mounting Adapter</b>        | <b>18</b> |
| 4.1 Choice of inserts                     | 18        |
| 4.2 Choice of Z-brackets                  | 19        |
| 4.3 Adapter assembly                      | 20        |
| 4.4 Place and adjust the adapter          | 20        |
| <b>5. Fitting the DL2002 Lathe on UMA</b> | <b>21</b> |
| 5.1 Examples                              | 22        |
| <b>6. Positioning DU2010 Drive Unit</b>   | <b>26</b> |
| <b>7. Machining</b>                       | <b>27</b> |
| <b>8. Follow-up</b>                       | <b>28</b> |
| <b>9. Maintenance</b>                     | <b>29</b> |
| <b>10. Trouble shooting</b>               | <b>30</b> |
| <b>11. Tips / Spare Parts</b>             | <b>31</b> |
| 11.1 Tips                                 | 31        |
| 11.2 Spare Parts                          | 31        |
| <b>12. Electrical Diagram</b>             | <b>32</b> |
| <b>13. Technical Specification</b>        | <b>33</b> |
| <b>14. CE-declaration of conformity</b>   | <b>34</b> |
| <b>15. Disposal instructions</b>          | <b>34</b> |
| <b>16. Guarantee</b>                      | <b>35</b> |

Read and follow this instruction manual before assembling, installing, operating, or servicing the equipment.

Original instructions  
Version: 08



## 1. Summary

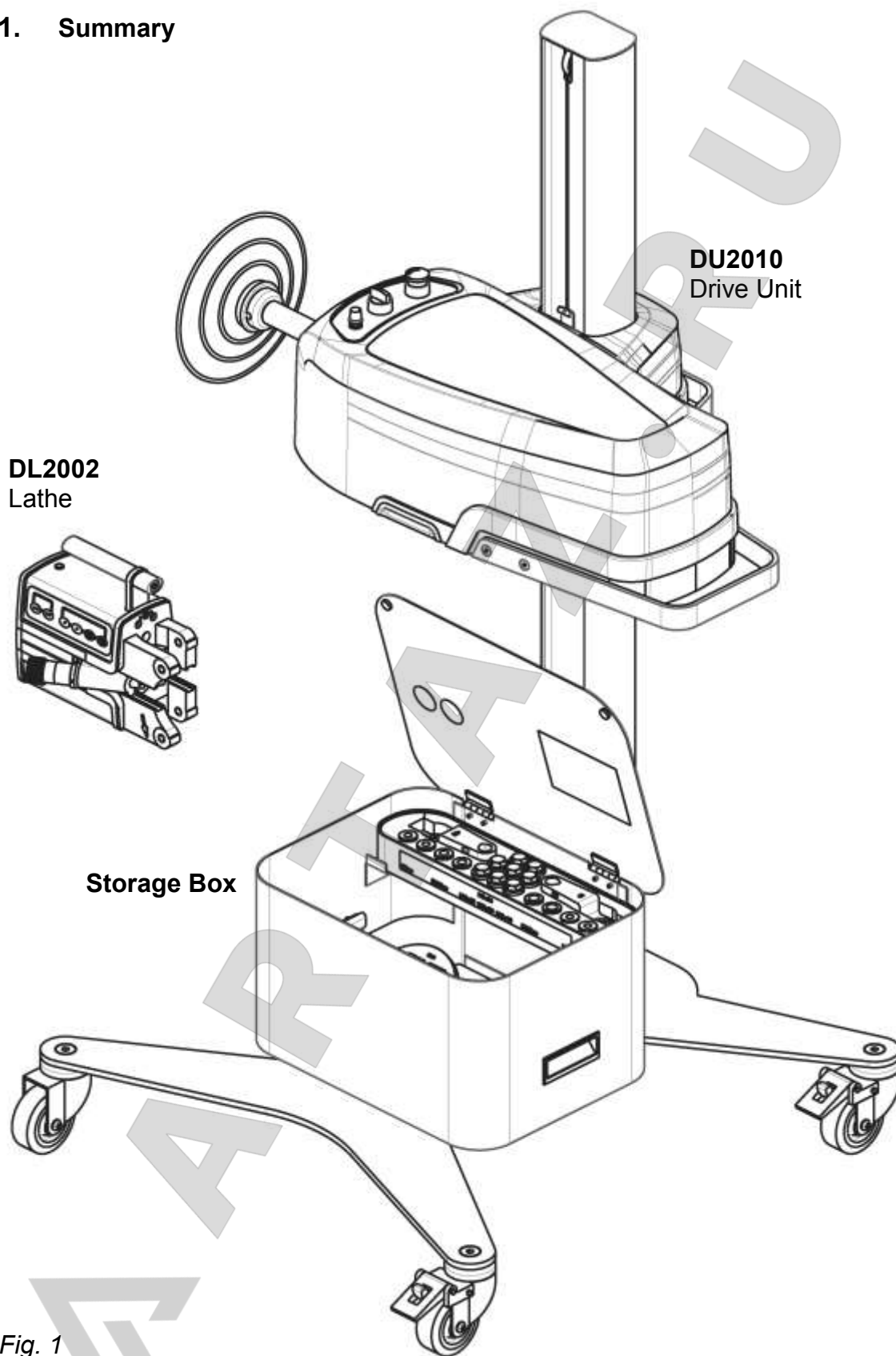
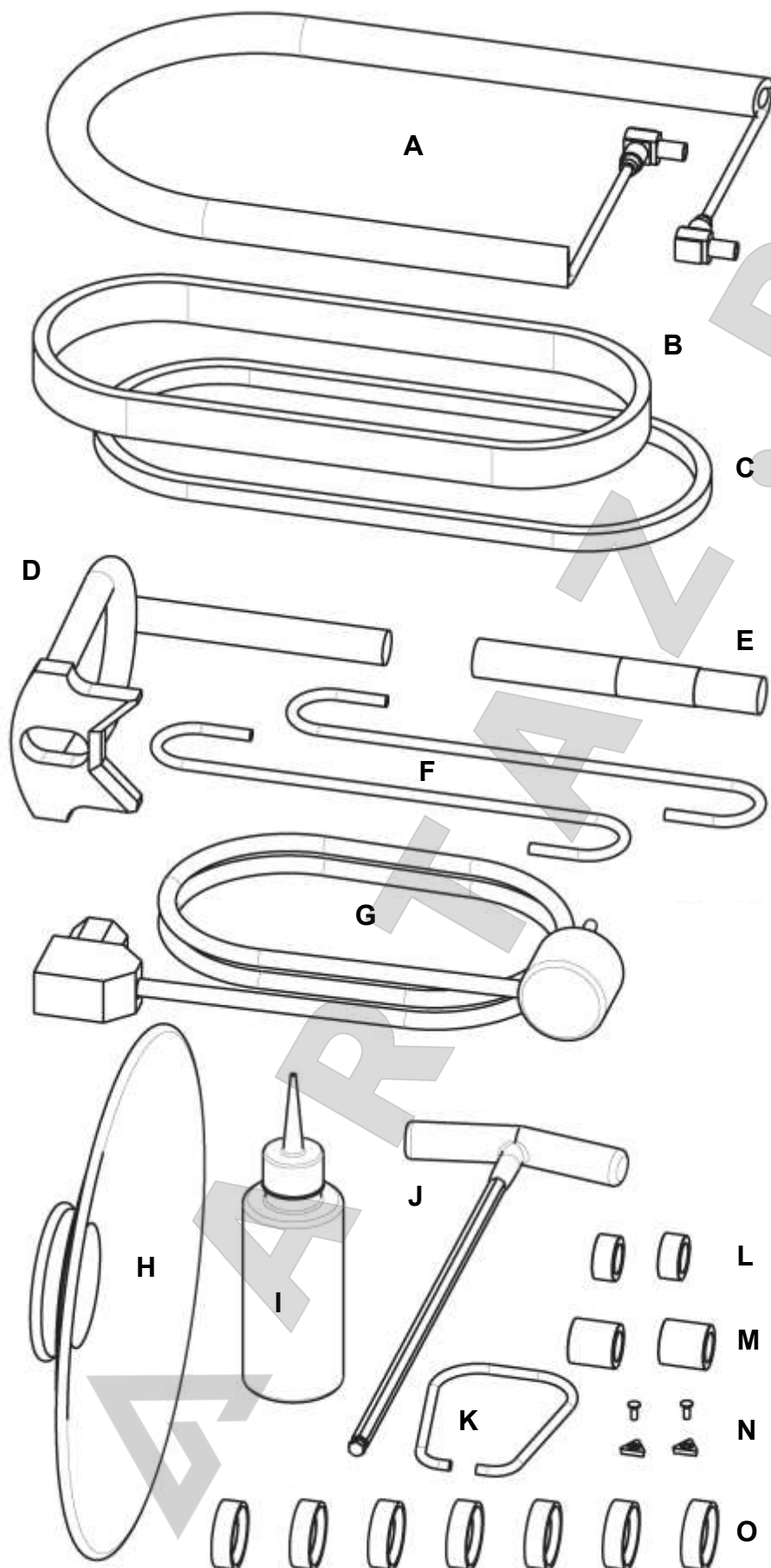


Fig. 1



- A. 36V cable
- B. Silencer band yellow
- C. Silencer band red
- D. Drive adapter
- E. Brush
- F. S-hook
- G. Cable
- H. Safety cover
- I. Oil
- J. Hex T-spanner
- K. Tool for cable working height
- L. Cylinder 12.5x10
- M. Cylinder 12.5x20
- N. Tool bits  
Screws M2.5
- O. Conical ring

Fig. 2

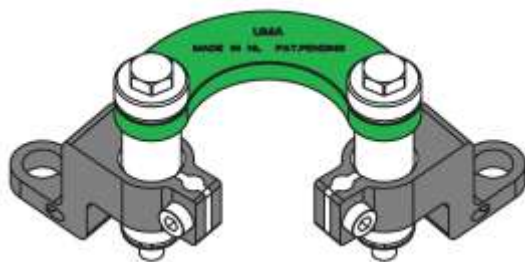


Fig. 3

UMA, Fig 3.  
 Universal Mounting adapter  
**Short Z-brackets** with hole  
 Ø16.2 mm/ 0.63 inch

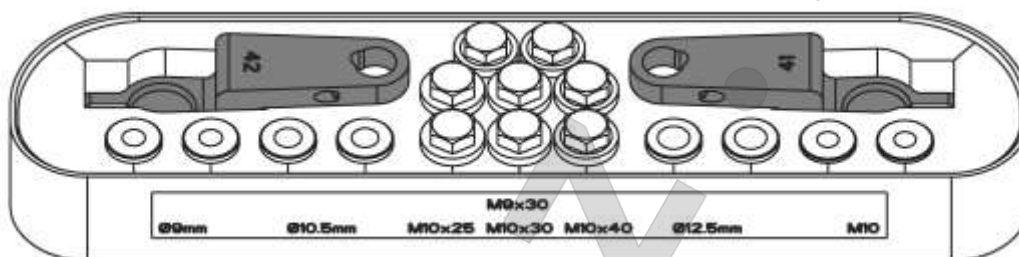


Fig. 4

UMA accessories, Fig 4.  
**Long Z-brackets** with hole  
 Ø16.2 mm/ 0.63 inch  
**Inserts without thread**  
 Ø9 mm / 0.35 inch  
 Ø10.5 mm/ 0.39 inch  
 Ø12.5 mm/ 0.47 inch  
**Inserts with thread**  
 M10 (metric)  
**Washers**  
 Ø24xØ11x4 / 0.94x0.43x0.16 in  
**Bolts**  
 M10x25 (metric)  
 M10x30 (metric)  
 M10x40 (metric)



## 2. Important Safety Instructions

When using this equipment, basic safety precautions should always be followed, including the following:

1. Read all instructions.
2. Care must be taken as burns can occur from touching hot parts.
3. Do not operate equipment with a damaged cord or if the equipment has been dropped or damaged until it has been examined by a qualified service person.
4. Do not let a cord hang over the edge of the table, bench, or counter or come in contact with hot manifolds or moving fan blades.
5. If an extension cord is necessary, a cord with a current rating equal to or more than that of the equipment should be used. Cords rated for less current than the equipment may overheat. Care should be taken to arrange the cord so that it will not be tripped over or pulled.
6. Always unplug equipment from electrical outlet when not in use. Never use the cord to pull the plug from the outlet. Grasp plug and pull to disconnect.
7. Let equipment cool completely before putting away. Loop cord loosely around equipment when storing.
8. To reduce the risk of fire, do not operate equipment in the vicinity of open containers of flammable liquids (gasoline).
9. Adequate ventilation should be provided.
10. Keep hair, loose clothing, fingers, and all parts of body away from moving parts.
11. To reduce the risk of electric shock, do not use on wet surfaces or expose to rain.
12. Use only as described in this manual. Use only manufacturer's recommended attachments.
13. ALWAYS WEAR SAFETY GLASSES. Everyday eyeglasses only have impact resistant lenses, they are not safety glasses.
14. The socket-outlet shall be installed near the equipment and shall be easily accessible.
15. The machine should only be operated by persons authorized to carry out maintenance on the brakes of a vehicle.
16. Do not use the equipment under the influence of drugs or alcohol, or if your judgment is impaired.
17. Always use the disc lathe DL2002 and the drive unit DU2010 together.
18. Only use the disc lathe DL2002 and the drive unit DU2010 as stipulated in this manual.
19. Do not overload the disc lathe DL2002 and the drive unit DU2010.
20. Follow the electrical specifications as stated on the information plates of both devices.
21. Keep the workplace tidy. A disorderly working environment can lead to accidents.
22. If the equipment is not being used, it should be packed away out of children's' reach.
23. Children must be kept clear of the equipment at all times.
24. No one else should be allowed to come in contact with the equipment or cables. Keep them clear of the working area.
25. Do not use the equipment in wet, humid environments, or where there is risk of explosion.
26. Do not use the motor (DU2010) below a level of 46 cm (18 inch) above the ground.
27. Always follow the safety regulations and the (dis-)assembly instructions provided by the car manufacturer when (dis-)assembling vehicle parts.
28. A 0.5 meter (20 inch) working area is required both next to the drive unit DU2010 and next to the disc lathe DL2002.



29. The drive unit DU2010 must be equipped with a safety guard (SK-508), as specified in this manual.
30. Make sure that the surface of the working area is level.
31. Maximum load capacity of top surface is 1 kg (2.2 Lbs).
32. Do not move the equipment while it is running.
33. Warning: machining generates hot chips of metal from the disc.
34. The accompanying risk of fire, injury or burns must be prevented by taking the following safety precautions; Wear protective clothing, work gloves, a dust mask. Check that a fire extinguisher is present.
35. If possible, always use the rubber silencer ring on the outer edge of the brake disc. This will minimize vibration and/or noise.
36. MAD cannot be held liable for customized attachments or modifications of the equipment.
37. Prior to using the equipment, damaged safety guards or other parts should be checked in order to ascertain that they still function properly.
38. Check the alignment of the moving parts and their connections, possible part faults, the set up and indeed any other conditions that might have an influence on the operation of the equipment.
39. If not otherwise indicated in the manual, damaged safety guards, cables, or other parts must be replaced or repaired by an recognized technician.
40. Defective electric components must be replaced by a recognized technician.
41. In the interest of effectiveness and safety, keep the tips sharp and the equipment clean.
42. Hand grips must be kept dry, clean and free from oil and grease.
43. Only maintain the equipment as described in this manual.
44. General repairs, repairs to damaged parts, as well as any other form of maintenance should only be carried out by a recognized technician (possessing thorough electrical and mechanical knowledge and experience) using genuine MAD spare parts.
45. Repairs and maintenance may only be carried out on the equipment if it has been switched off and if the plug has been removed from the mains.
46. Prior to repairs on the drive unit DU2010, carefully short-circuit the connectors of the capacitor to prevent electric shock injuries.
47. Always use original M.A.D. parts in carrying out repairs or maintenance.
48. Machining the brake discs can affect the brake performance. After machining check if the deceleration meets the requirements of the law and the car manufacturer.

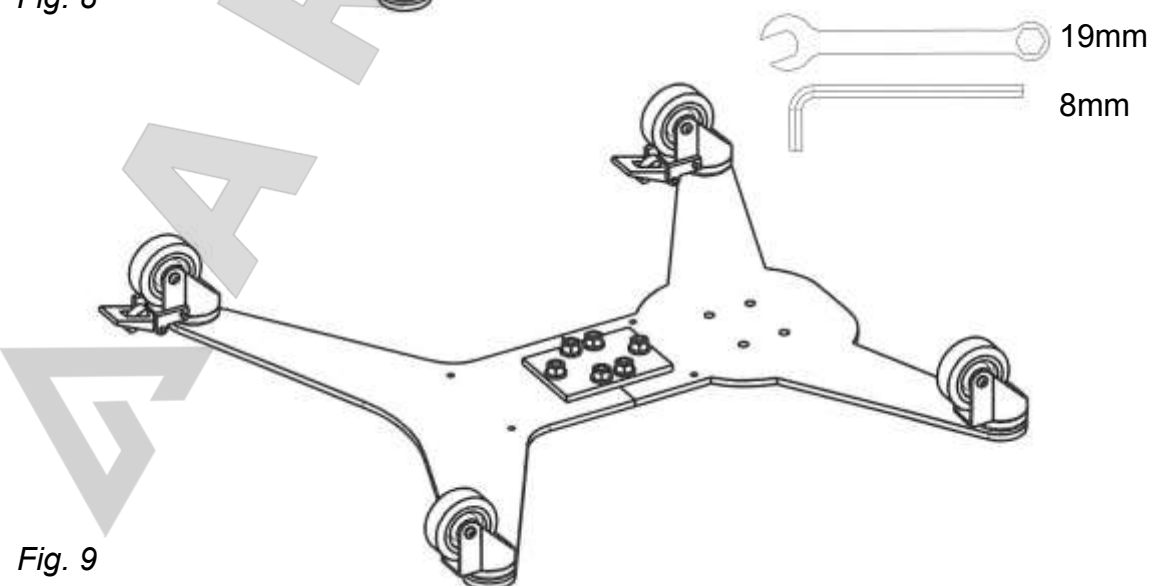
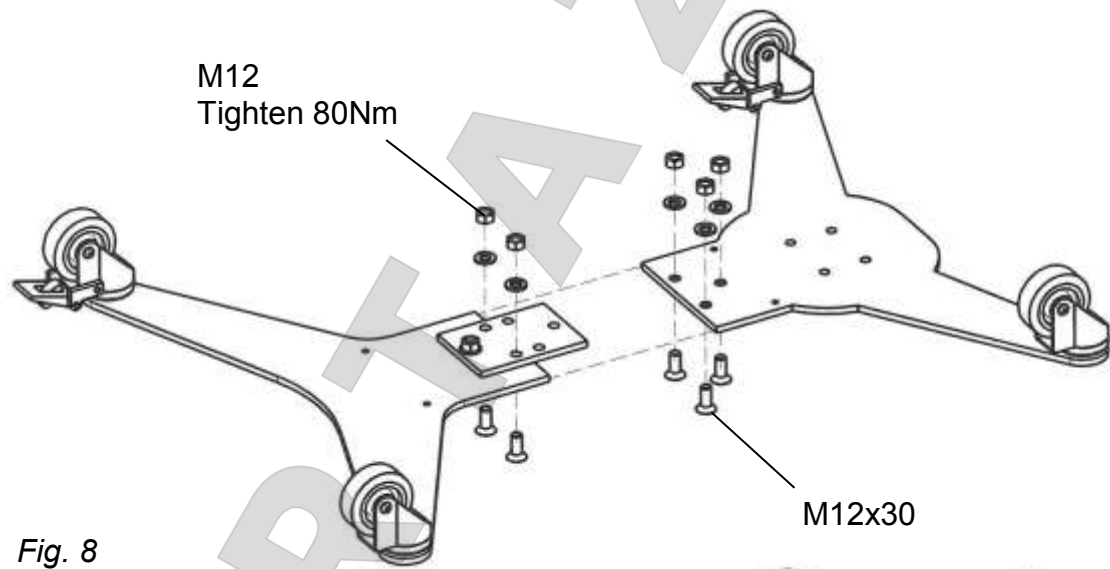
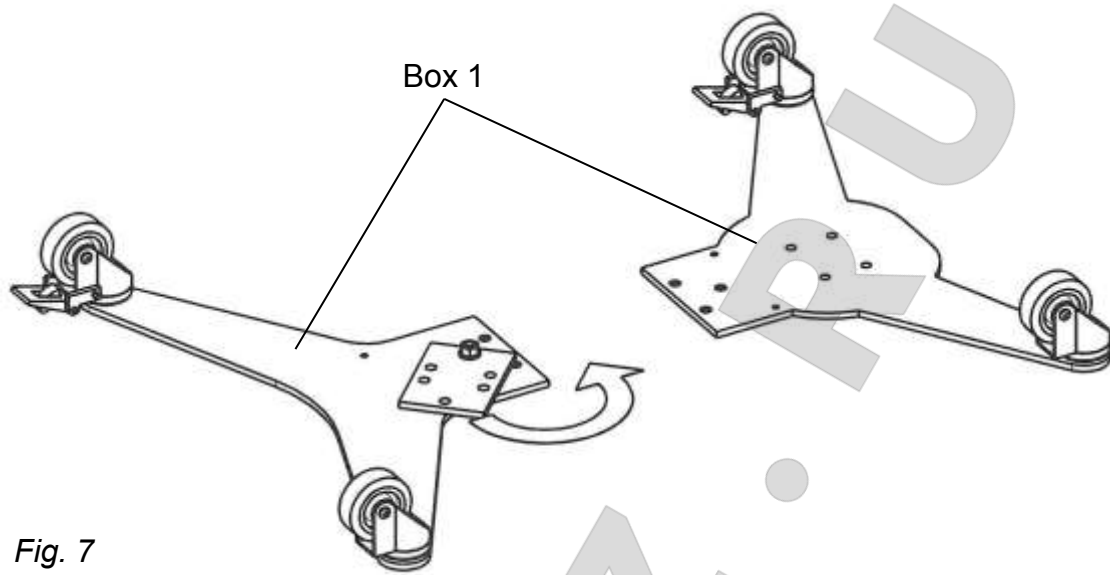
**SAVE THESE SAFETY INSTRUCTIONS**

Fig. 5

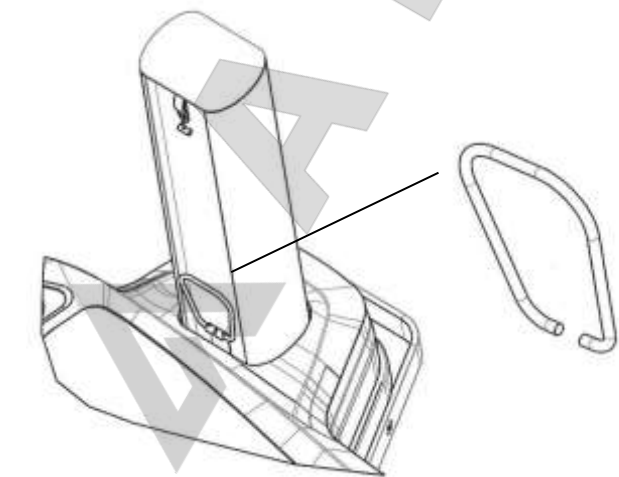
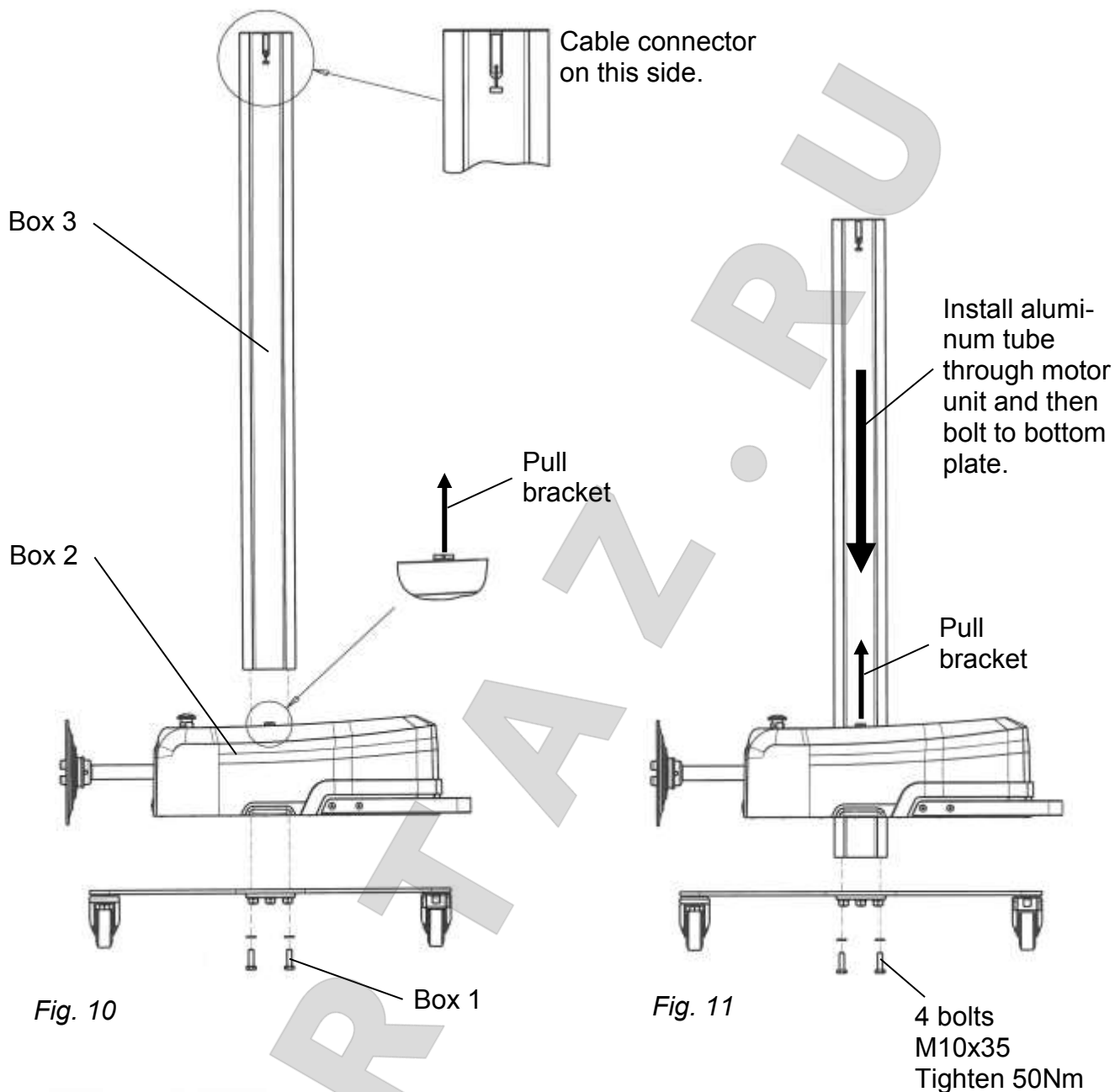


Fig. 6

## 2.1 First Installation







en | 10 | DA2002 | Important Safety Instructions

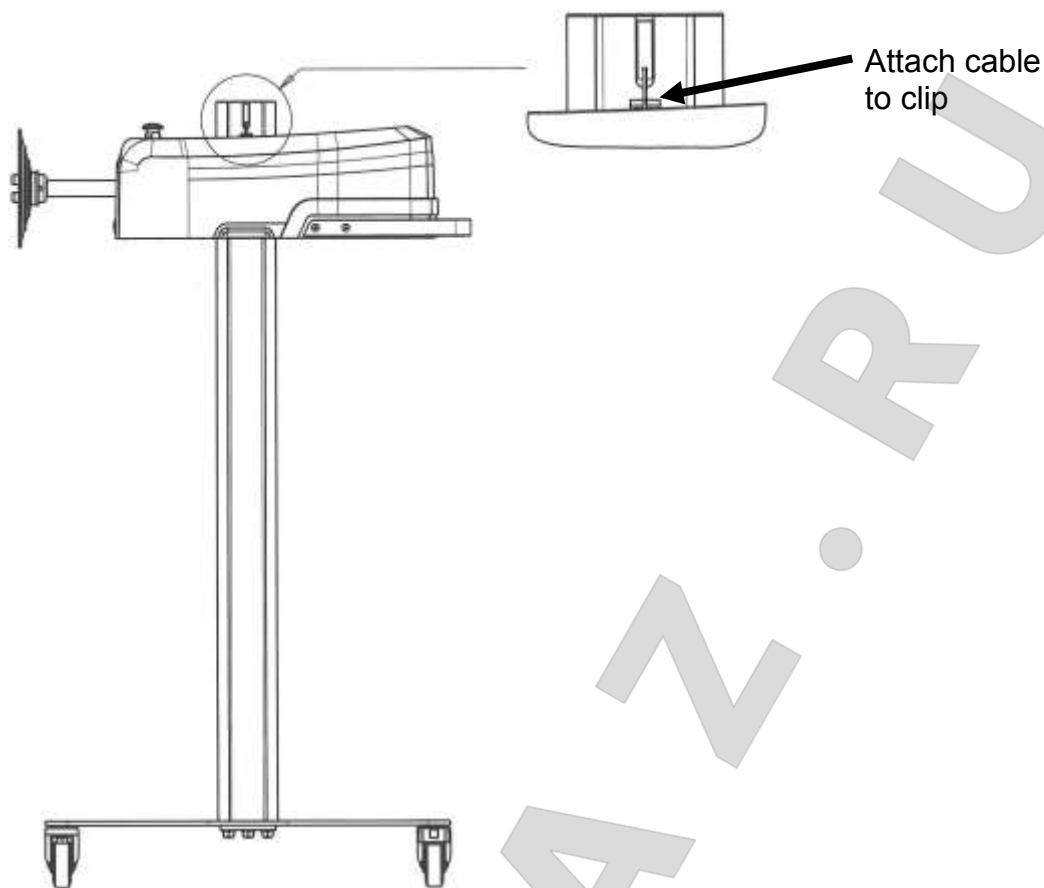


Fig. 13

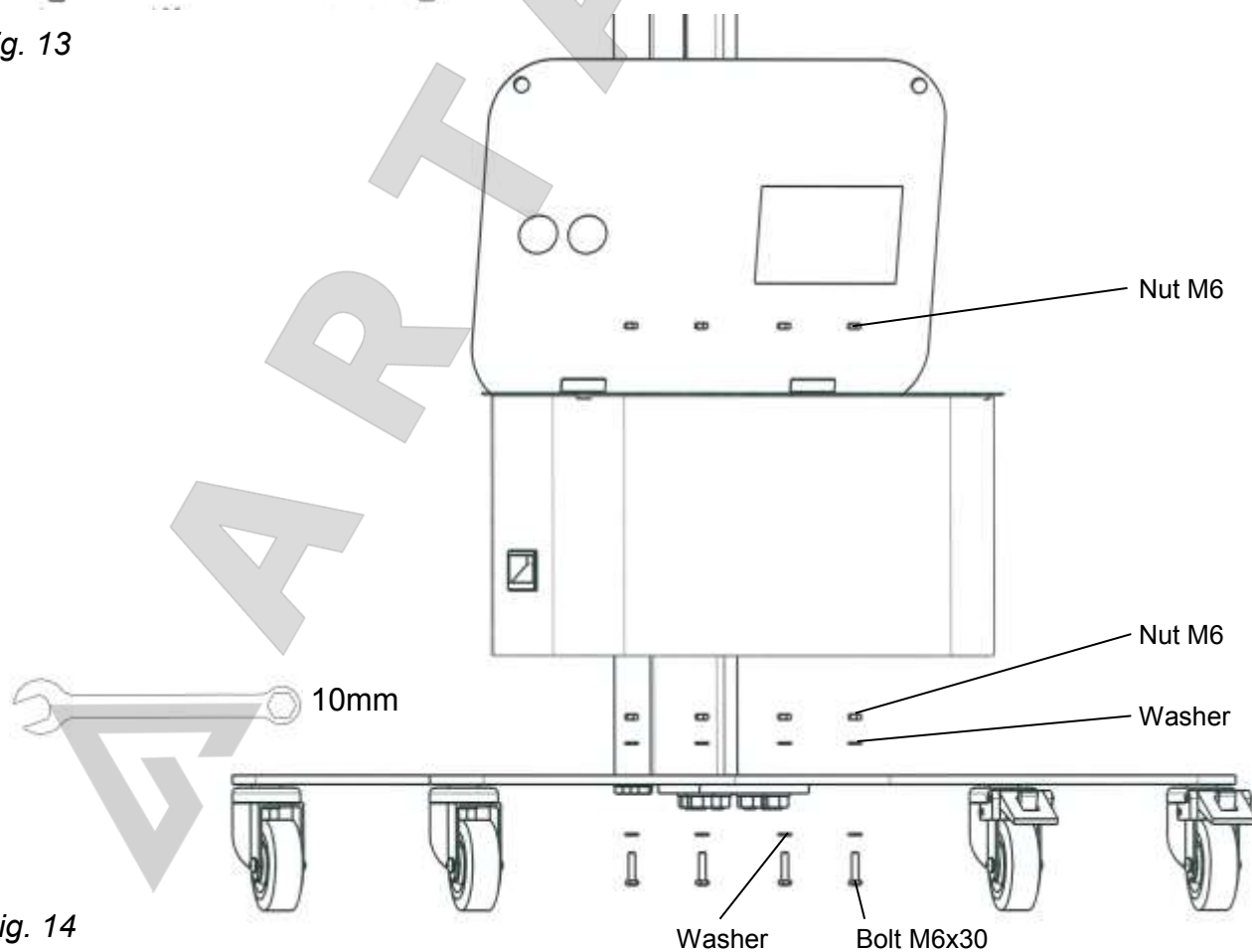
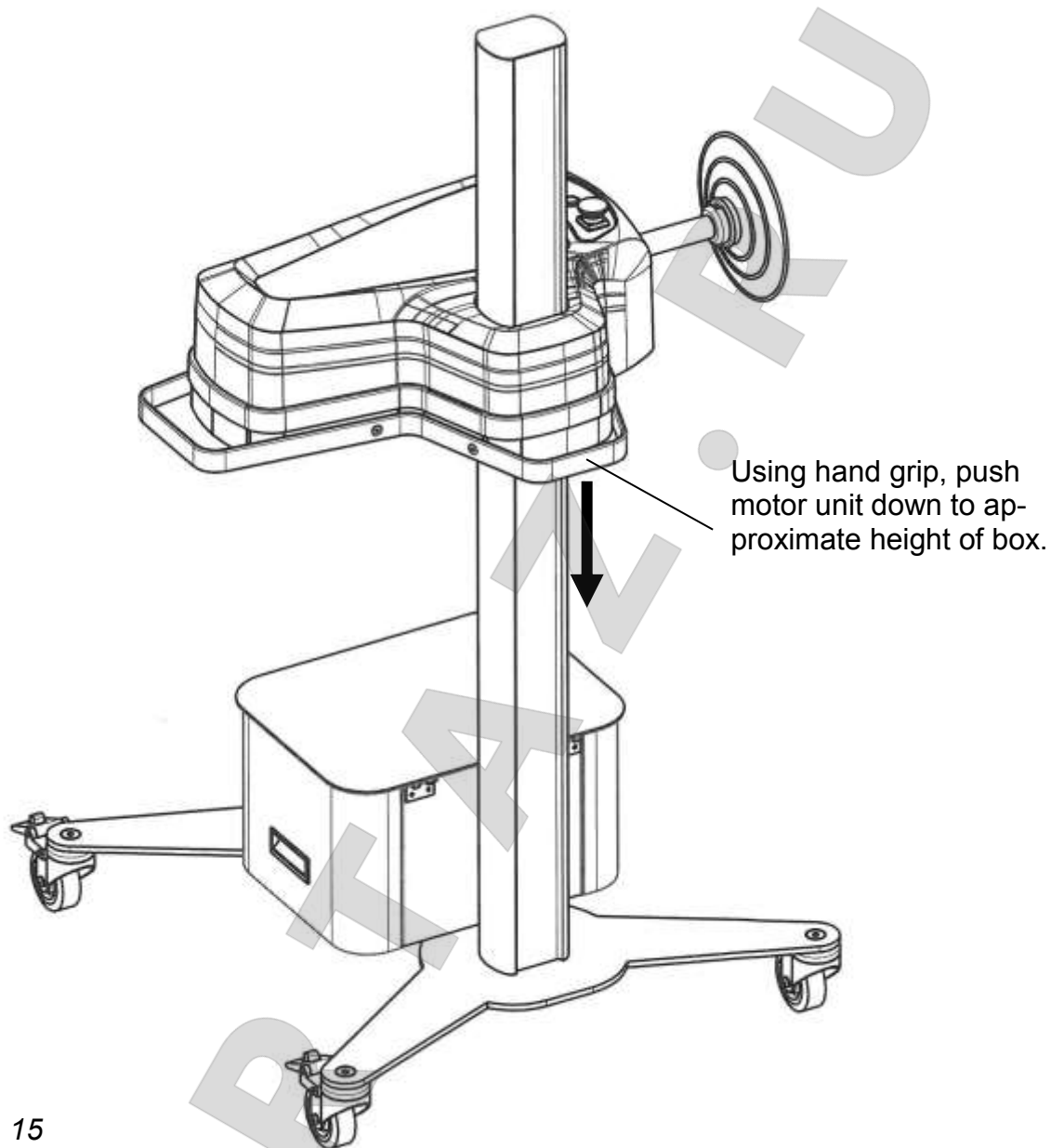


Fig. 14



## 2.2 Controls DL2002 Lathe

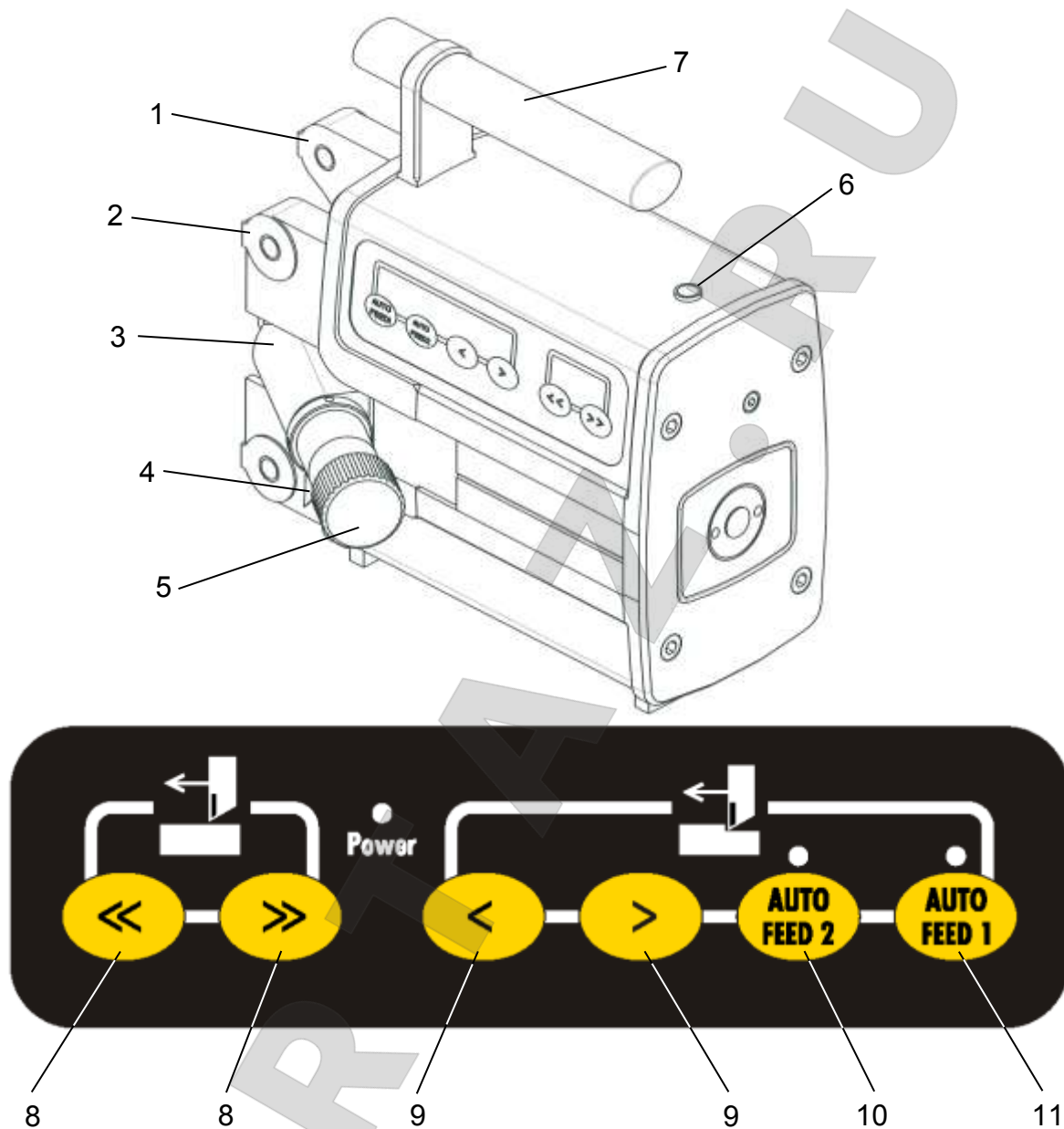
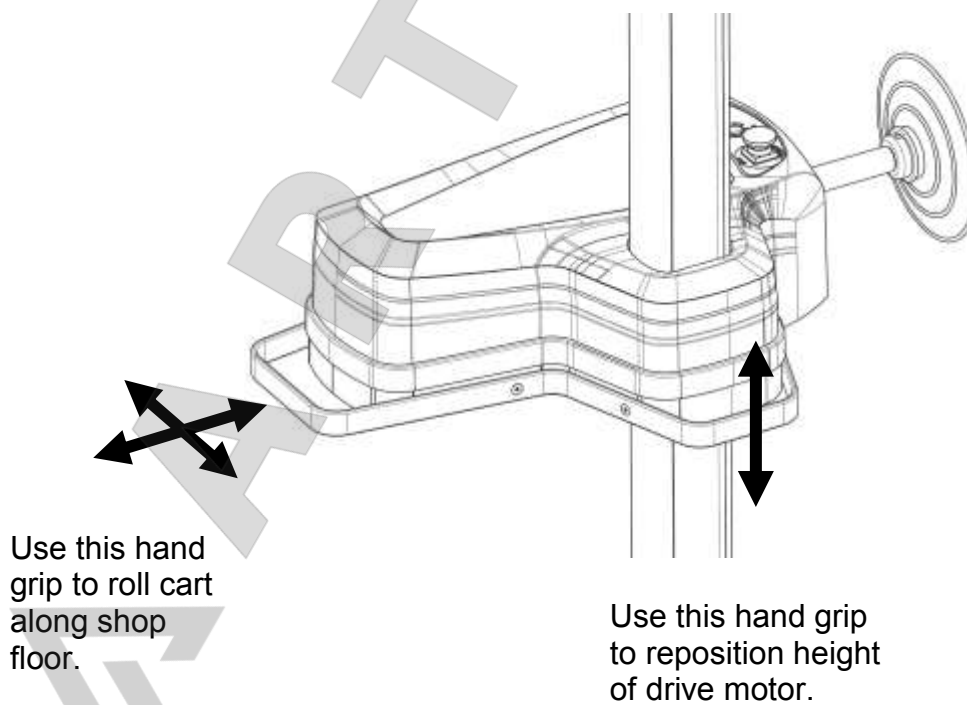
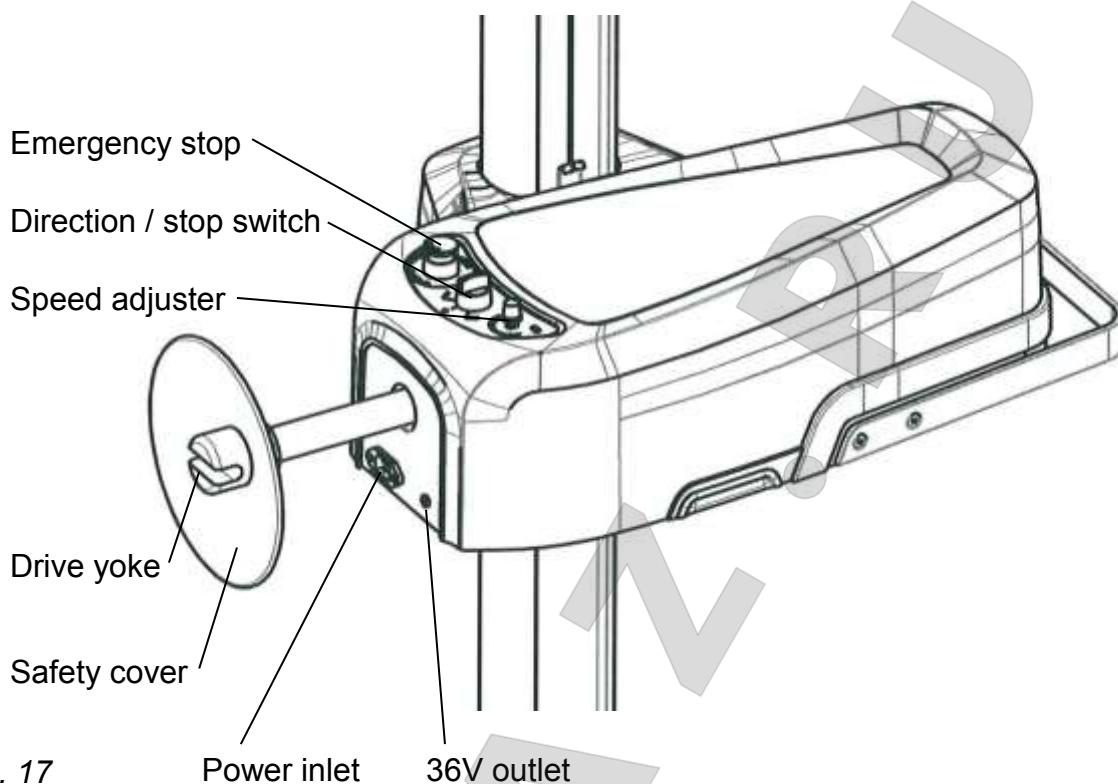


Fig. 16

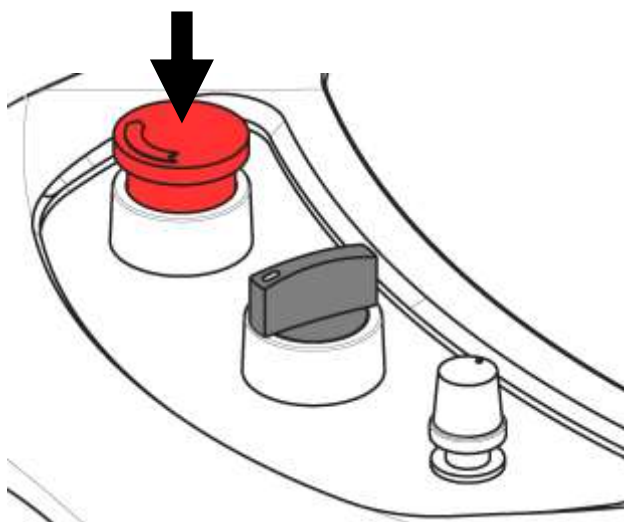
1. Long mounting ear
2. Short mounting ear
3. Slide
4. Direction indicator arrow
5. Cutting depth adjustment knob
6. 36V power plug
7. Handle
8. << and >> Slides high-speed control buttons
9. < and > Slides low-speed control buttons
10. Autofeed 2 - Slides high-speed automatic feed
11. Autofeed 1 - Slides low-speed automatic feed

## 2.3 Controls DU2010 Drive Unit

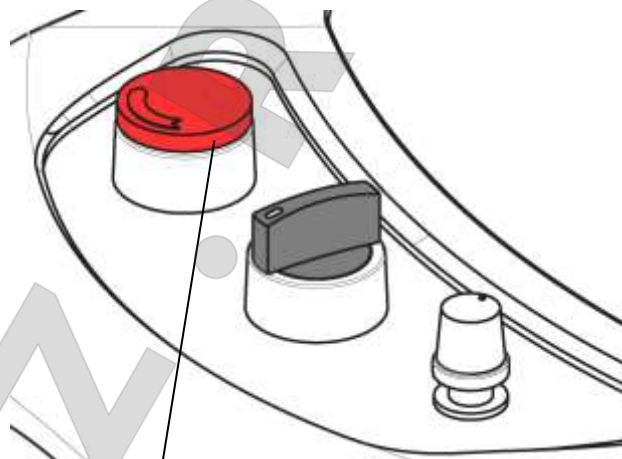


**en | 14 | DA2002 | Important Safety Instructions**

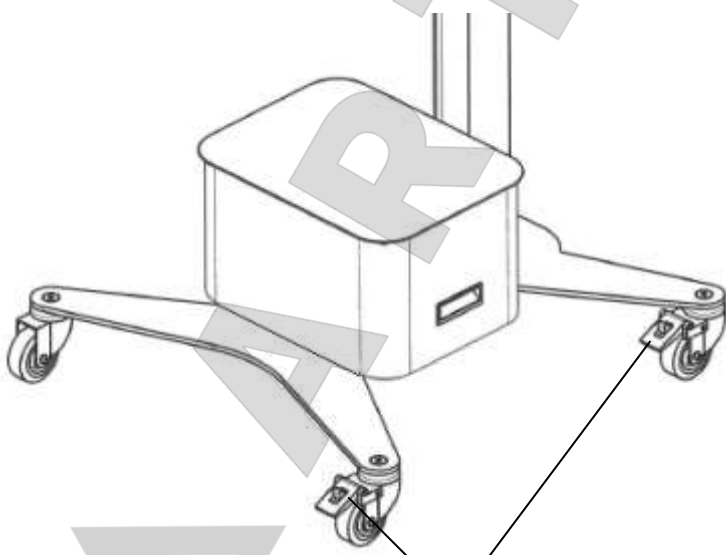
In case of emergency, power off the drive unit by pressing the emergency stop button. In a safe situation, the emergency stop is reset by rotating the knurled ring under the stop button, clockwise. The drive unit is reset by rotating the motor switch to position 0.

*Fig. 19*

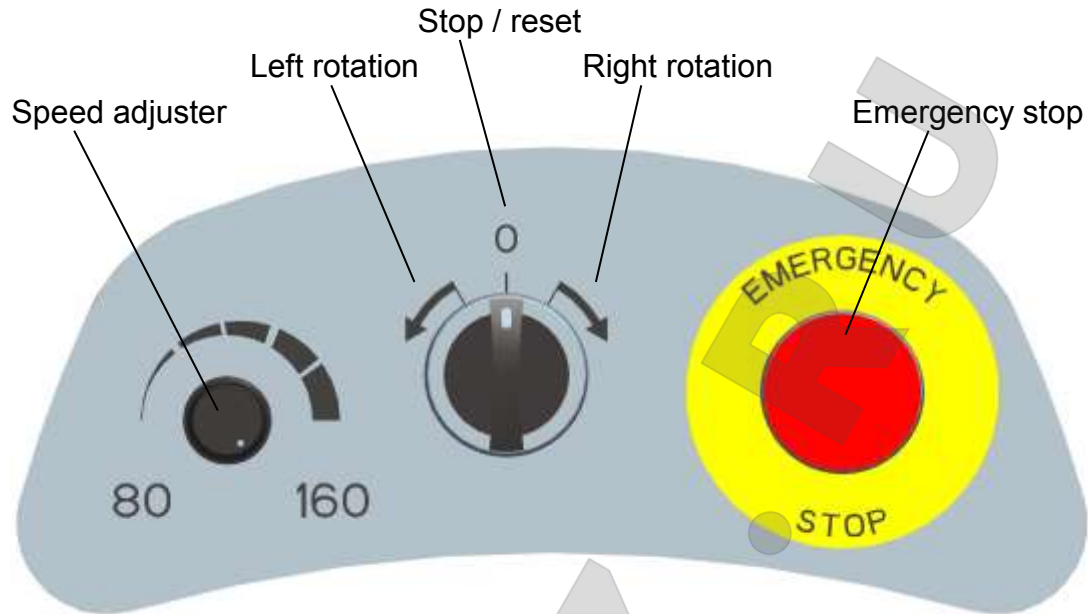
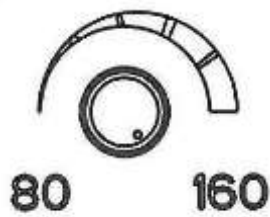
Press down for emergency stop.

*Fig. 20*

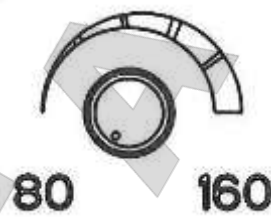
Rotate bottom ring clockwise to reset emergency stop.  
Rotate direction switch to 0 to reset drive unit.

*Fig. 21*

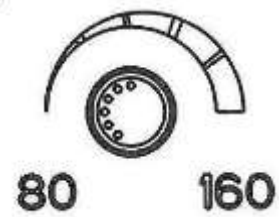
Lock caster wheels during machining.

*Fig. 22*

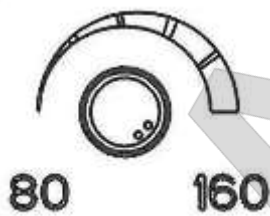
160 rpm  
Normal use, maximum speed.

*Fig. 23*

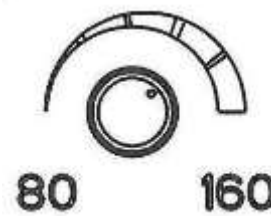
80 rpm  
Minimum speed.

*Fig. 24*

80 - 120 rpm  
Use only autofeed 1 on the Lathe.

*Fig. 25*

160 - 155 rpm  
When using a two-post car lift, gradually adjust motor speed to reduce vehicle sway.

*Fig. 26*

130 rpm  
Maximum torque, use on 4WD cars.

*Fig. 27*

### 3. Preparation



Fig. 28



Fig. 29

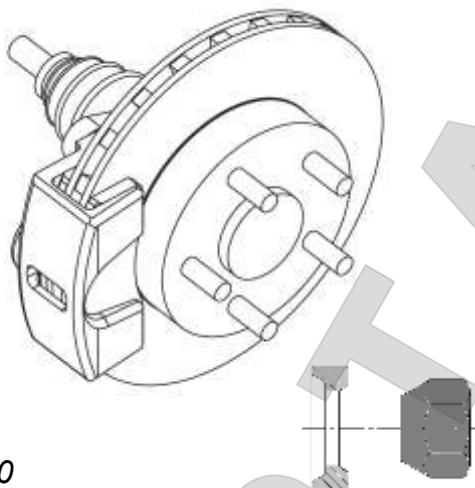


Fig. 30

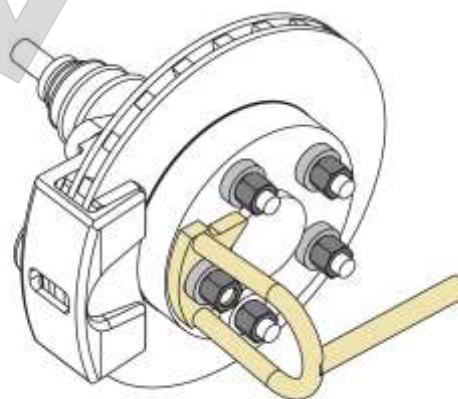


Fig. 31

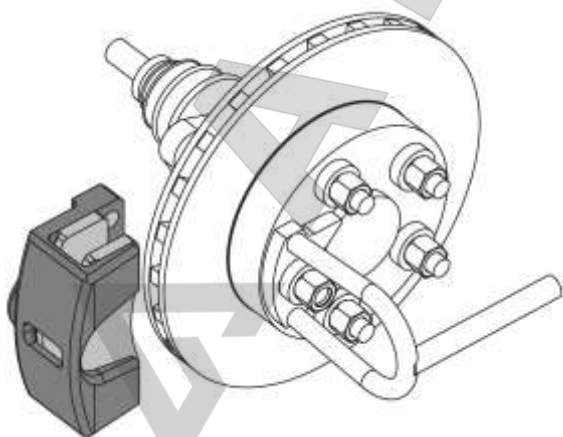


Fig. 32

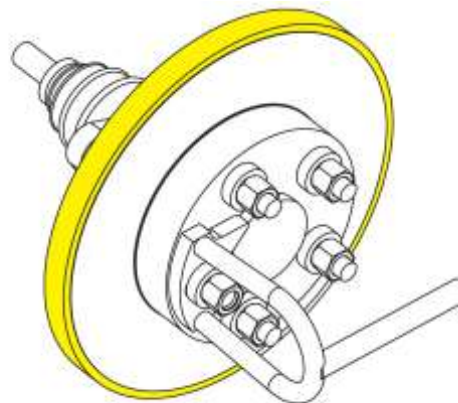


Fig. 33



1. Place vehicle on car lift and put transmission in neutral.
2. Raise lift and place vehicle at correct working height, Fig. 28.
3. Check wheel bearing play on both sides of vehicle Fig. 29.
4. If necessary, adjust wheel bearing tolerances as described by the workshop manual.
5. Immediately after removing the wheel, secure the brake disc to the hub to prevent dirt particles from accumulating between disc and hub.  
Use a brake pedal depressor to lock the brake disc.  
NOTE: Brake discs are not all mounted to a hub with a screw or nut.
6. Remove the wheel and secure the brake disc with the wheel nuts (or bolts) and conical rings, Fig. 30.
7. Mount the drive adapter to one of the wheel nuts (or bolts), Fig. 31.
8. The V-shape of the drive adapter must seat firmly along the edge of the hub.
9. Tighten the wheel nuts or bolts evenly to 50 Nm (37 Ft-Lbs).
10. Remove the wheel on the other side of the vehicle and secure that brake disc with two wheel nuts (or bolts) and conical rings.
11. Remove the brake pedal depressor.
12. Check the thickness of the brake disc, to ensure that the disc will not be below minimum thickness after machining.
13. Refer to the service manual for the minimum brake disc thickness.
14. If the brake disc is below minimum thickness, it must be replaced. Machining of a disc below minimum thickness is not permitted.
15. If the brake disc is thicker than the discard size, determine the maximum amount that could be machined off, for each side of the brake disc.
16. Remove the complete brake caliper and hang it on the S-hook, Fig. 32.
17. Check that the brake line and caliper do not come in contact with the drive shaft (or any other rotating part).
18. Remove rust and dirt from the mounting surface of the caliper mounting lugs.  
The lugs must be clean, as they are the reference point for machining the brake surface.
19. Fit the rubber silencer band around the outer edge of the brake disc to help reduce noise and vibration, Fig. 33.
20. Connect the cable to the Drive Unit and the mains power supply.
21. Connect the 36V cable between Drive Unit and Lathe.
22. Set the motor switch to position 0, then unlock the emergency switch.
23. Move the slides and bit holders of the Lathe in the most rear position. (with adjustment knobs cutting depth and << or >> on the control panel. The green LED of the Lathe should be on.
24. In this position the tool bits cannot be damaged by touching the brake disc.

## 4. Fitting Mounting Adapter

### 4.1 Choose the inserts

Vehicle knuckle:  
**Without thread**

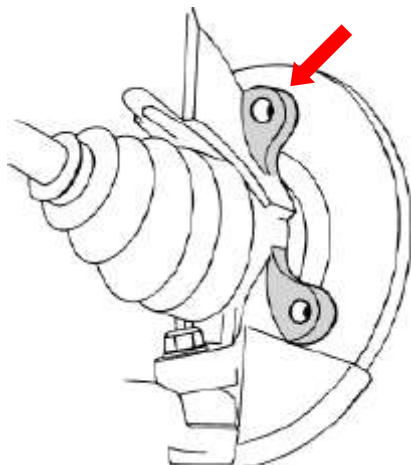


Fig. 34

Adapter:  
Use **inserts with thread**

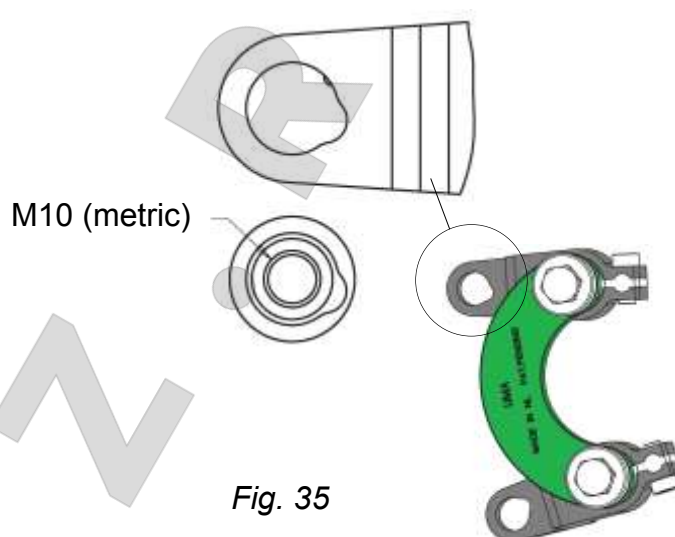


Fig. 35

Vehicle knuckle:  
**With thread**

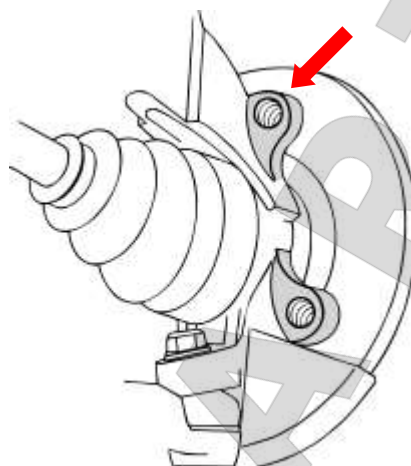


Fig. 36

Adapter:  
Use **inserts without thread**, in the correct size:

Ø16.2 mm / 0.63 inch  
(without insert)

Ø9.0 mm / 0.35 inch

Ø10.5mm / 0.39 inch

Ø12.5 mm / 0.47 inch

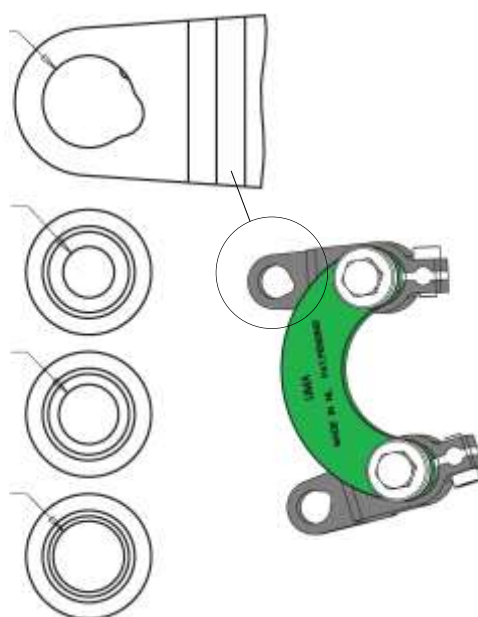


Fig. 37

## 4.2 Choose the Z-brackets

For normal size discs and knuckles.

**Short adapter:**

Use z-brackets 39 and 40.

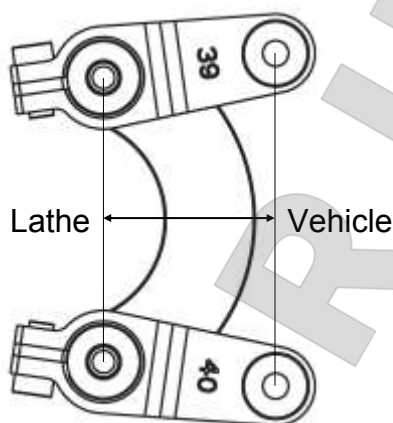


Fig. 38

For large discs and/or deep placed knuckle mounting position.

**Long adapter:**

Use z-brackets 41 and 42.

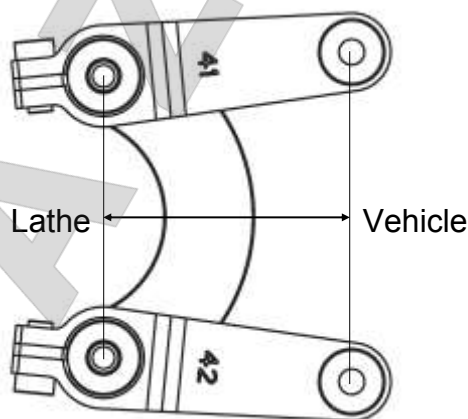


Fig. 39

In some cases it may be necessary to go between short and long:

**Medium adapter:**

Use z-brackets 39 and 42  
or: 40 and 41

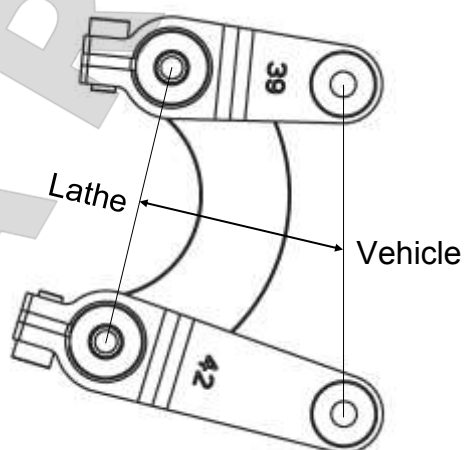


Fig. 40

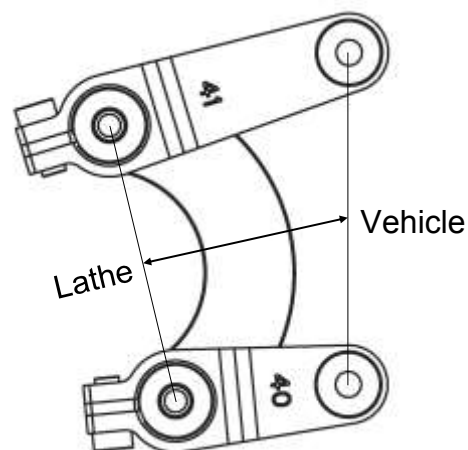


Fig. 41

**en | 20 | DA2002 | Fitting Mounting Adapter**
**4.3 Assemble the adapter**

- A.** Connector bow
- B.** Z-bracket short (39-40) or long (41-42)
- C.** Inserts with- or without thread

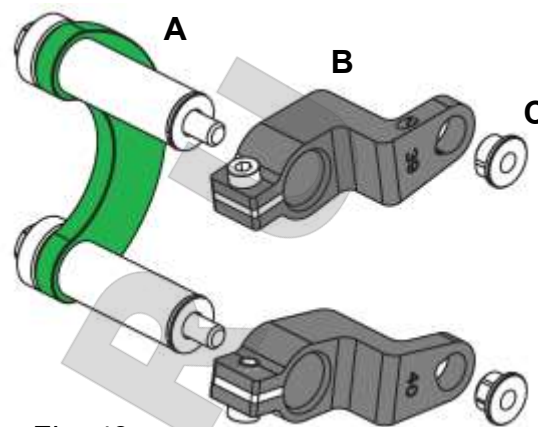


Fig. 42

**4.4 Fit and adjust the adapter**

1. Check the space between lathe and disc: Keep the space between lathe and disc short as possible, but at least 5 mm (0.04 inch). Fig 43.
2. Options to correct this dimension;
  - Choose long side or short side of the Lathe
  - Use the adapter with longer or shorter z-bracket(s) Fig 38-41.
3. Do not use air tools when mounting or removing the mounting adapter and/or the Lathe.
4. Fit the adapter on the car and adjust the adapter height

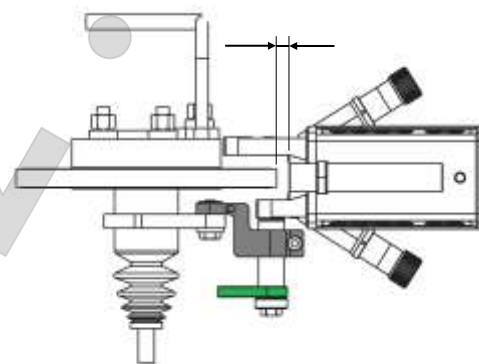


Fig. 43

**Adapter with M10 metric inserts;**

Mount the adapter to the brake caliper ears, using the M10 bolts supplied, Fig 34-35.

**Adapter with 9, 10.5, 12.5 mm or no inserts;**

Using the original caliper bolts, mount the adapter to the threaded caliper ears, Fig. 36-37.

- a. Face the bow toward the axle.
  - b. Ensure the correct-length bolts are used. When the bolts are fully inserted, they must not touch the brake disc.
  - c. If necessary, use the spacer tubes provided to achieve the correct bolt length.
  - d. Ensure the slide piece hex head bolts are loose.
5. Position the slide piece in the center of the hub. Then hand tighten the UMA mounting adapter M10 bolts, Fig. 44.

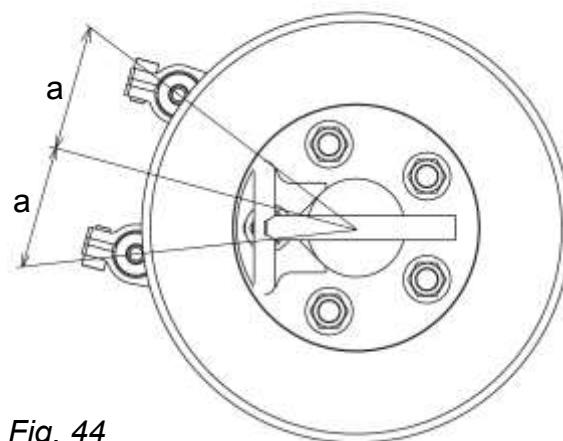


Fig. 44



## 5. Fitting the Lathe on the adapter

1. Bring the Lathe into correct position, Fig. 43.
2. Select mounting on the long or the short mounting ear, depending on following facts;
  - a. The distance between outer ridge of the brake disc and the DL2002 must be large enough to insert the rubber silencer.'
  - b. The distance between outer ridge of the brake disc and the DL2002 must be as short as possible.
3. If necessary mount the Lathe upside down, Fig. 48-49.
4. Mount the Lathe on the slide piece by using the hand knobs.
5. Position the lathe so that the Lathe centerline is aligned with the brake disc centerline. Fig 45-47.
6. Ensure the Lathe does not make contact with the brake disc.
7. To secure the slide piece to the mounting bracket, tighten one of the hex-head bolts using the hex T-spanner wrench provided.
8. Tighten all bolts in the following order, to the specified torque:
  - a. M10 mounting bolts on the calliper ears: torque 50 Nm (37 Ft-Lbs).
  - b. Original calliper bolts (larger or the same as M10) torque: 50 Nm (37 Ft-Lbs).  
Brake calliper bolts M8: torque: 25 Nm (18 Ft-Lbs).  
Brake calliper bolts M9 torque: 30 Nm (22 Ft-Lbs)
  - c. Hand knobs: torque to 50 Nm (37 Ft-Lbs).
  - d. Mounting adapter hex-head bolts: torque to 25 Nm (18 Ft-Lbs).
9. Verify the brake disc rotates freely with no parts dragging or coming in contact with other parts.

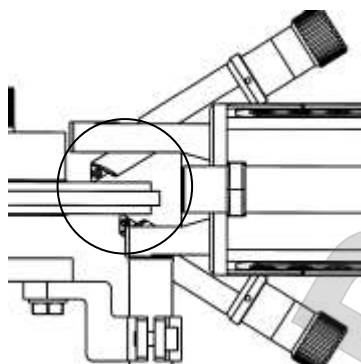


Fig. 45

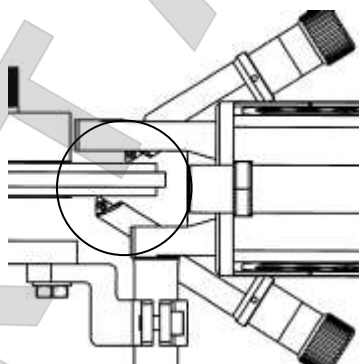


Fig. 46

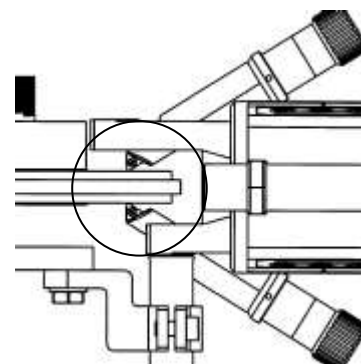


Fig. 47

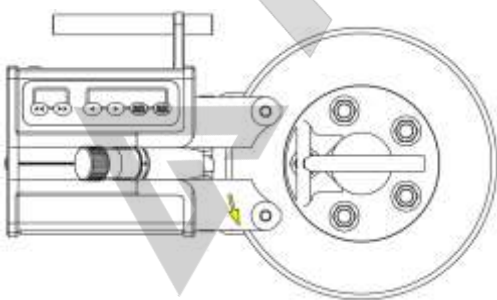


Fig. 48

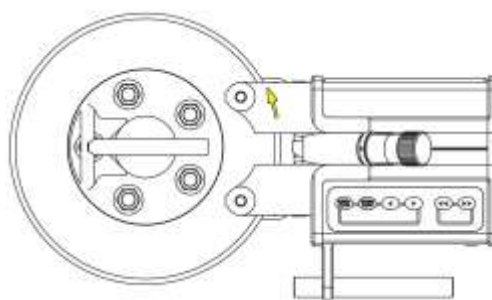


Fig. 49

## 5.1 Examples

Adapter with short z-brackets and with M10 metric insert, on hub with normal disc size.

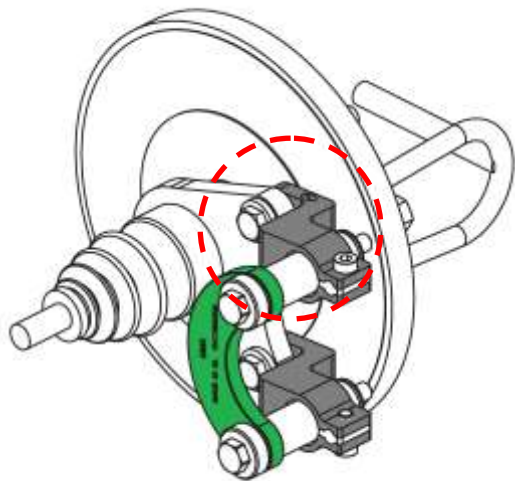


Fig. 50

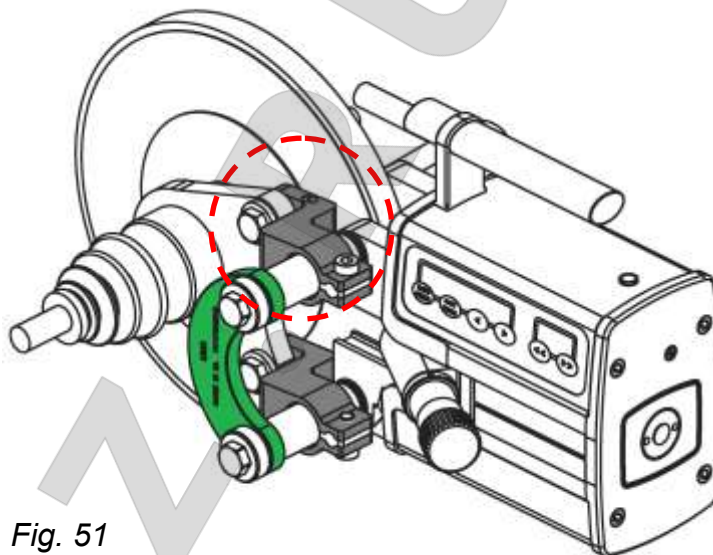


Fig. 51

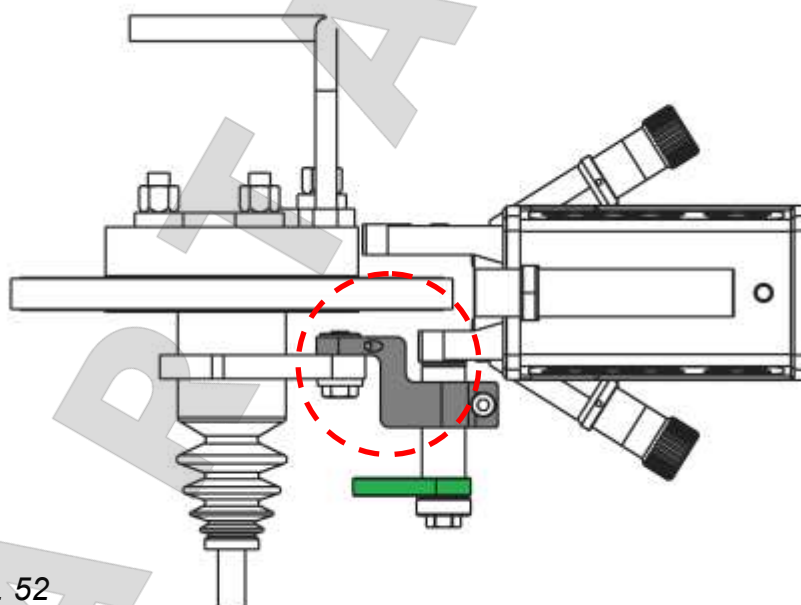


Fig. 52

Adapter with long z-brackets and with M10 metric insert, on hub with large disc size.

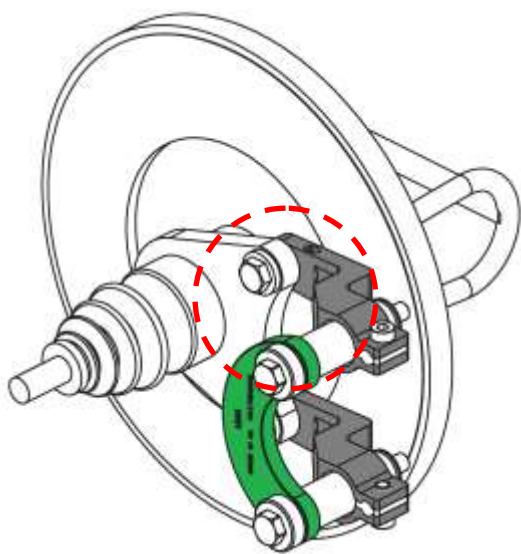


Fig. 53

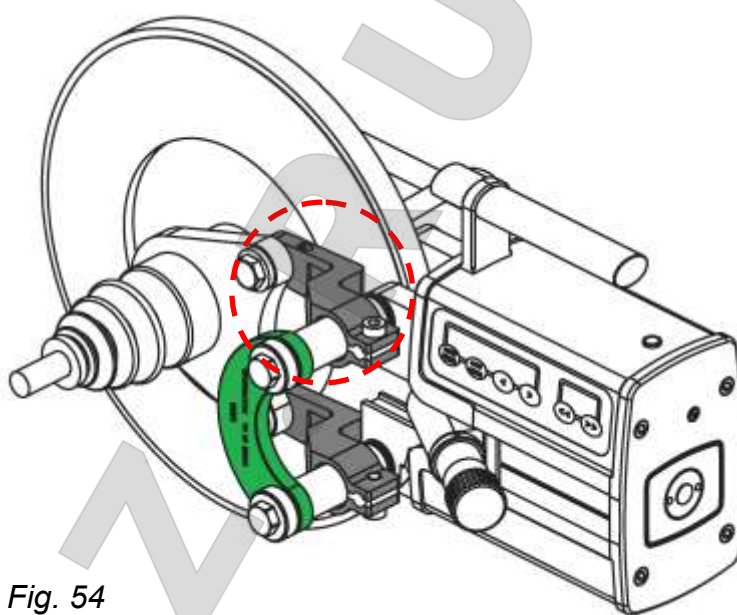


Fig. 54

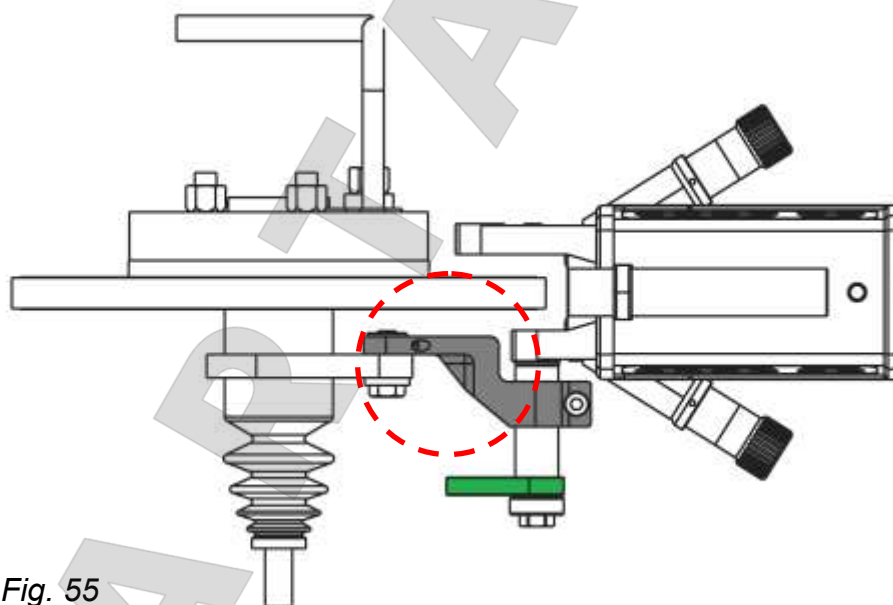


Fig. 55

## en | 24 | DA2002 | Fitting DL2002 Lathe on UMA

Adapter with short z-brackets and with insert without thread, on hub with normal disc size.

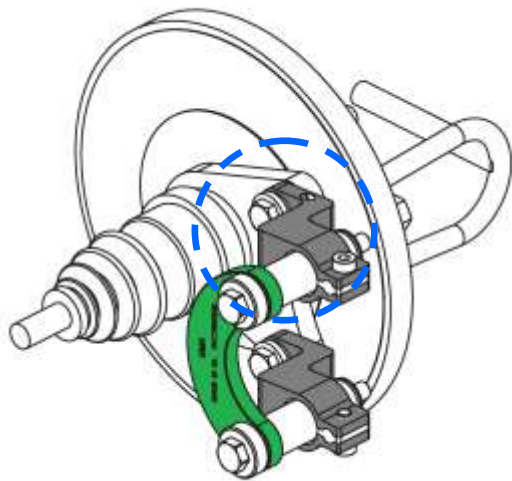


Fig. 56

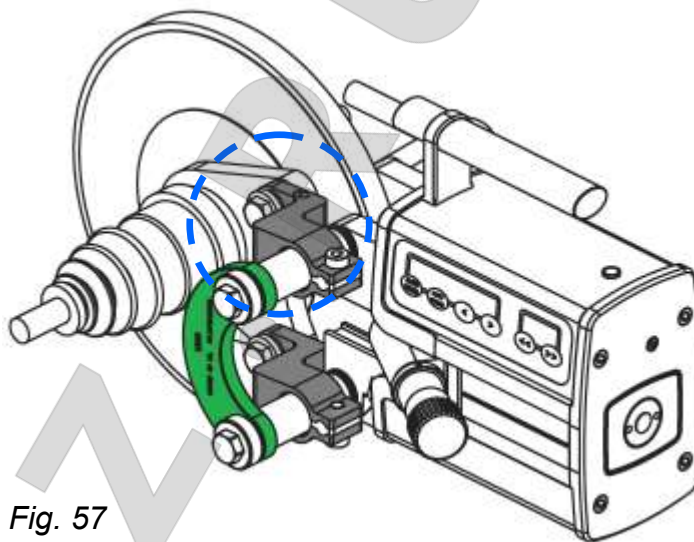


Fig. 57

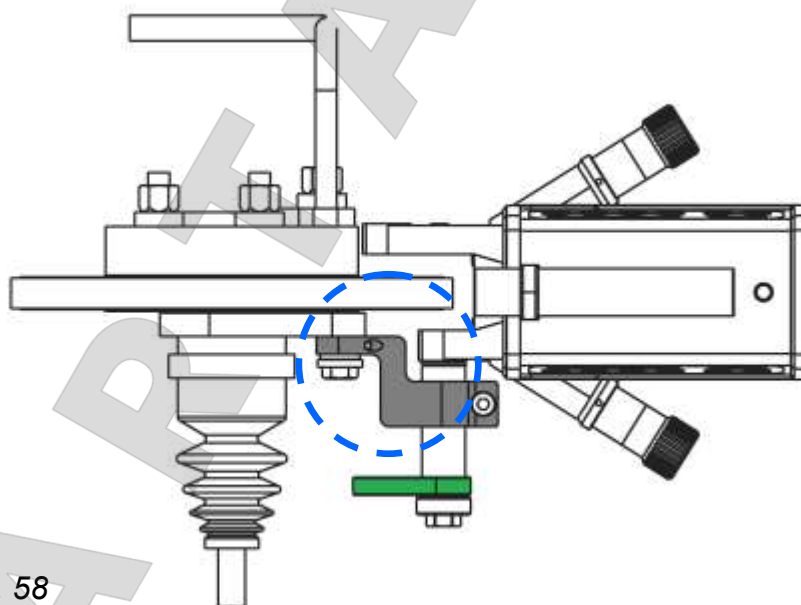


Fig. 58



Adapter with long z-brackets and with insert without thread, on hub with large disc size.

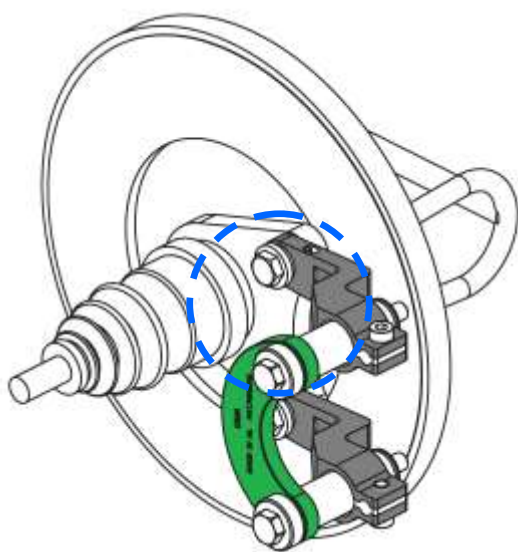


Fig. 59

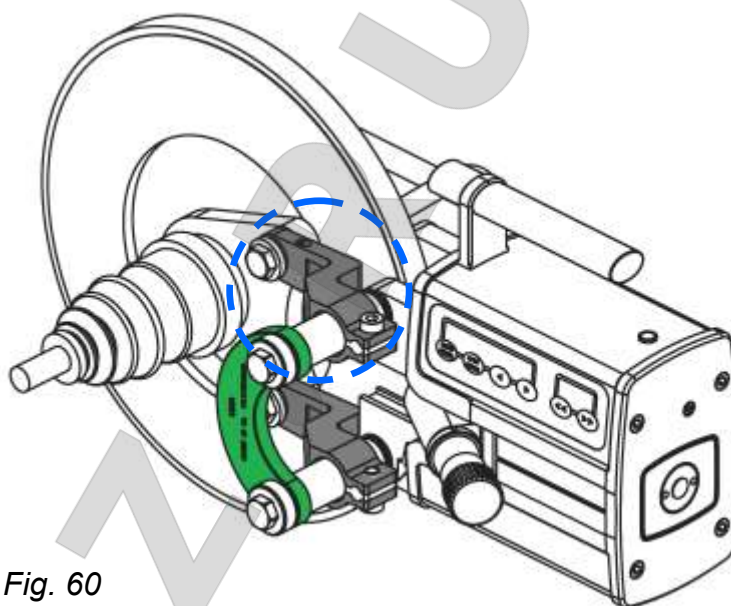


Fig. 60

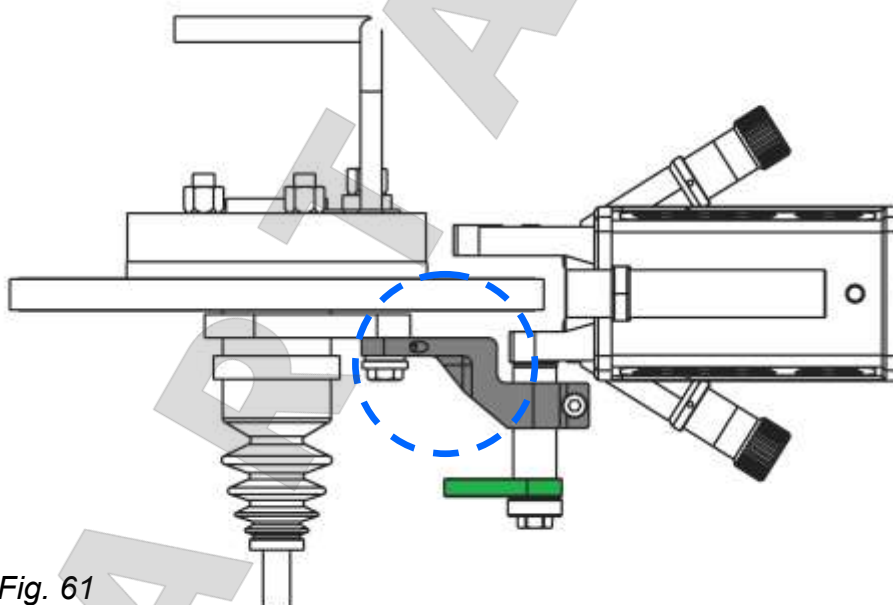
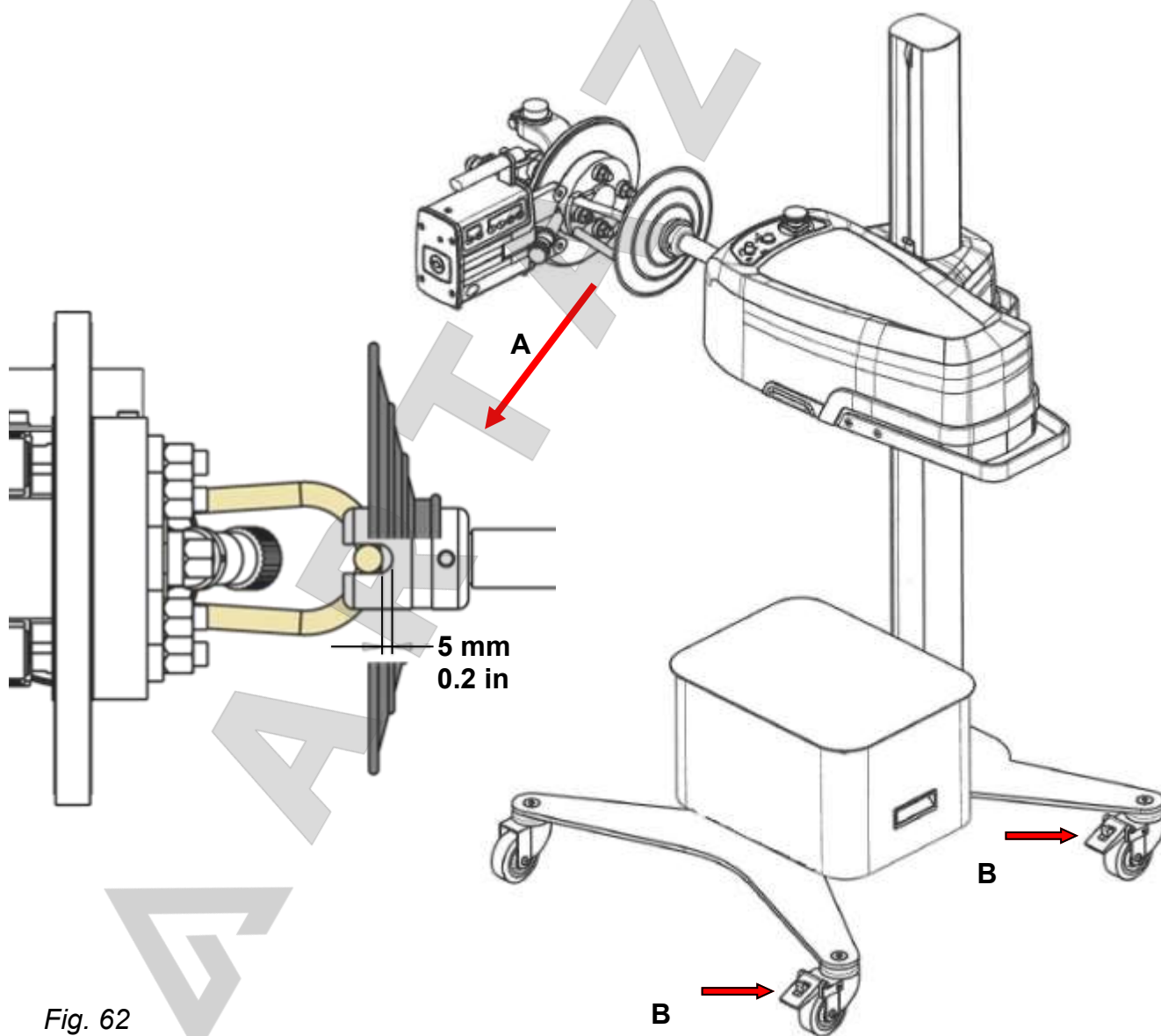


Fig. 61

## 6. Positioning DU2010 Drive Unit

1. Turn drive adapter horizontal.
2. Align the DU2010 Drive Unit with the hub of the disc.
3. Position the Drive Unit to the correct height, by grasping the hand grip on the drive unit and sliding the unit up or down along the mounting post. See fig. 18, page 13.
4. Slide the drive yoke onto the drive adapter, leaving a 5 mm (0.2 inch) space, fig. 62 A. Drive yoke must align with the center of the hub.
5. Lock the caster wheels to lock the stand in place, Fig. 62 B.
6. Check that the brake disc is free to rotate, with no parts dragging or blocking.
7. **NOTE:** The drive shaft and brake disc on the other side of the vehicle could start turning when the lathe drive unit is turned on.



## 7. Machining

1. Determine the correct rotation direction of the Drive Unit, see arrow on the Lathe, fig. 63.
2. Place the motor switch on the drive unit to the desired rotation direction. Fig. 22-27 on page 15. Depending on vehicle type, set the turning speed to:
  - 4WD vehicles - turning speed 130 rpm
  - All other vehicles - maximum turning speed 160 rpm
  - In case of unwanted swing of the vehicle -on a two post ramp- correct the speed slightly.
3. If there are large wear ridges on either surface of the brake disc, remove the ridges without exceeding the maximum cutting depth.
4. Operate the slides of the Lathe until the tool bits are at the middle of the brake surface.
5. Slowly turn the adjustment knobs clockwise, until the tool bits just begin cutting into the brake disc.
6. Move the slides carefully to the hub of the brake disc, fig. 64.
7. When using the positive-angle tool bit, the adjustment knob may be turned a maximum of 16 clicks.
8. When using the straight-tool bit, the adjustment knob may be turned a maximum of 4 clicks.
9. One click equals 0.05 mm (0.002 inch). Fig. 63.
10. Set the adjustment knobs (clockwise) on the selected value (minimal 0.05 mm, maximal 0.8 mm), (minimal 0.002 inch, maximal 0.03 inch).
11. Select autofeed 1 or autofeed 2 (normal use). Fig. 16, page 12.
12. Start the autofeed by pushing the autofeed button once.
13. After machining, stop the Lathe by pushing the autofeed button a second time.
14. Then stop the drive unit, by placing the drive switch to 0.
15. Verify that both sides of the disc are completely machined.
16. Repeat the machining if necessary.
17. Check that the brake disc is not machined thinner than the specified replacement size indicated in the repair manual. If the brake disc is thinner than allowed, the disc must be replaced.

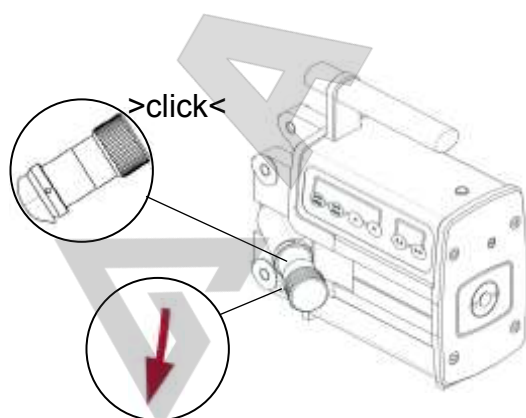


Fig. 63

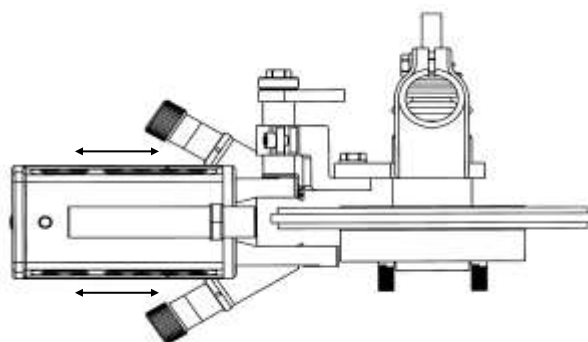


Fig. 64

## 8. Follow-up

1. Rotate the adjustment knobs counterclockwise until the tool bit holders are completely retracted.
2. Retract the slides by pressing the << or >> button.
3. Disconnect the 36V power cable and mains cable.
4. Remove the Lathe.
5. Remove the mounting adapter, by removing the mounting bolts in reverse order.
6. Remove the rubber silencer from the brake disc, Fig. 65.
7. Remove the drive adapter from the hub.
8. Note that the brake disc must remain mounted to the hub with at least two wheel nuts/bolts.
9. Repeat the procedure on the brake disc on the other side of the vehicle. See page 17.
10. To prevent unbalanced braking, always machine both brake discs on the same axle.
11. Clean the surrounding area of the brake disc and make sure there are no metal chips on the ABS components.
12. Make the brake pad surfaces parallel and flat. Replace the brake pads when necessary.
13. Install the brake pads and brake calipers according to the repair manual.
14. In some cases locking fluid or replacing of the caliper bolts is prescribed in the repair manual, every time the bolts are removed.
15. Torque the caliper bolts according to the repair manual.
16. Pump the brake pedal a few times to set the brake pads and disc.
17. Place a brake pedal depressor to lock the brake disc. Fig. 66.
18. Remove the wheel nuts/bolts and the conical rings.
19. Install the wheel according instructions in the repair manual.
20. Tighten the wheel nuts/bolts to the specified torque setting.
21. Check the brake fluid level and top off the fluid level as specified in repair manual.

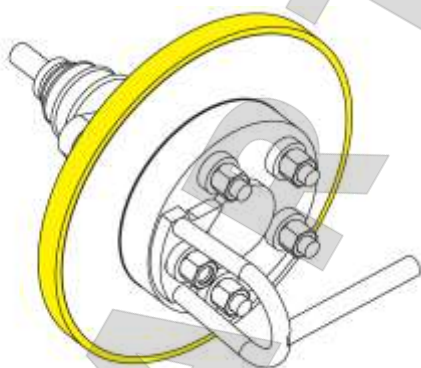


Fig. 65

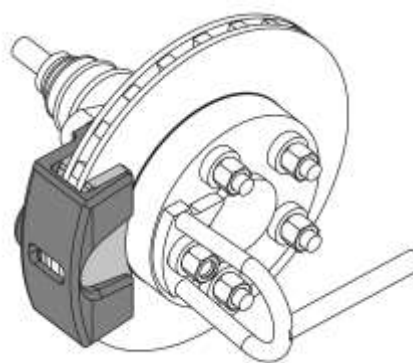


Fig. 66

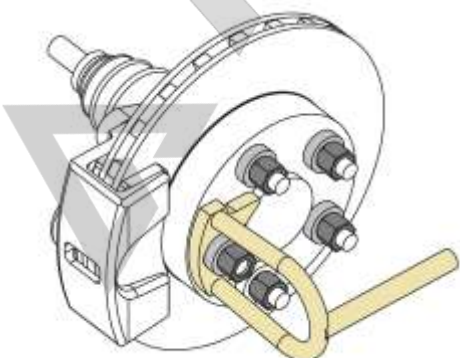


Fig. 67

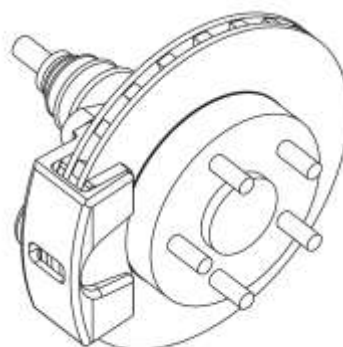


Fig. 68

## 9. Maintenance

Before carrying out maintenance activities, read the safety regulations contained in this manual.

- A. Ensure the bits are sharp and not damaged prior to each use. The bits should be rotated frequently and replaced every 10 vehicles.
- B. Clean the slides every 10 vehicles. Clean the guides between the block and the slide with a brush, then apply a small amount of Lathe oil.
- C. Clean the bit holder every 50 vehicles. To do this, first turn the adjustment knob counterclockwise until the bit holder is completely out of the slide. Then clean and lightly grease the holder. When reinstalling the bit holder, point the slot toward the outside of the Lathe
- D. On a weekly schedule, inspect cables and extension cables for damage and immediately replace them as necessary.

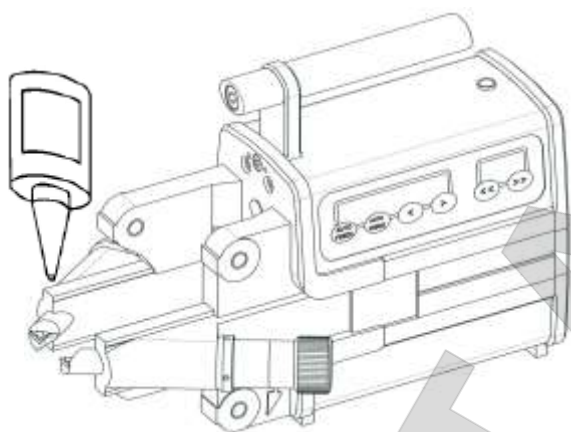


Fig. 69

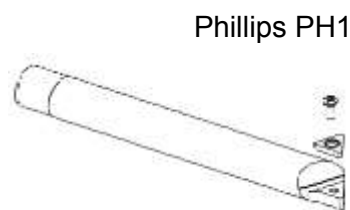


Fig. 70

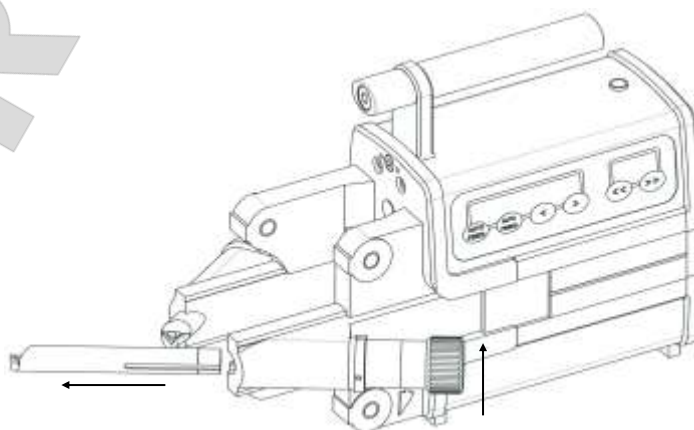


Fig. 71

## 10. Troubleshooting

| Trouble                            | Cause                          | Solution  |
|------------------------------------|--------------------------------|---|
| Rough surface or heringbone effect | Vibration                      | <ul style="list-style-type: none"><li>• Check rubber silencer band</li><li>• Check Lathe mounting</li><li>• Tighten all bolts M10 and larger with torque 50 Nm (37 Ft-Lbs) before starting work</li><li>• Use conical ring</li><li>• Mount Lathe close to the hub</li></ul> |
|                                    | Wheel bearing play             | Set/replace   |
|                                    | Cutting depth too deep         | <ul style="list-style-type: none"><li>• Maximum 0.2 mm (0.8 mm with pos. angle tool bit)</li><li>• Maximum 0.008 inch (0.03 inch with pos. angle tool bit)</li></ul>  |
|                                    | Worn tool bit                  | Turn or replace   |
|                                    | Tool bit loose                 | Tighten screw   |
|                                    | Wrong direction of rotation    | See arrow on Lathe  |
| Drive unit not stable              | Not aligned with drive adapter | Align   |
|                                    | Drive adapter does not center  | Re-install and center   |

Tab.1.

- Wheel nuts/bolts should always be evenly tightened.
- In the event of an electrical failure, temporary operation of the slides is possible by first inserting a 6mm Allen wrench in the hole in the back plate and turning the screw with the wrench.



## 11. Tips / Spare Parts

### 11.1 Tips

- While assembling the Lathe, ensure that the spacing between the brake caliper ears and Lathe is even both above and below.
- Rotate or change the bits frequently to ensure a fresh, sharp cutting edge.
- Prior to machining, verify that the bits will be able to machine the entire surface of the brake disc.
- A special brochure detailing various options for your lathe is available through your supplier.

### 11.2 Spare parts

- Replacement parts can be ordered through your supplier. When ordering parts, refer to the parts list included with the lathe. Please provide the lathe serial number when ordering.
- Store this instruction manual and parts list in the storage box of the Lathe.



## 12. Electrical Diagram

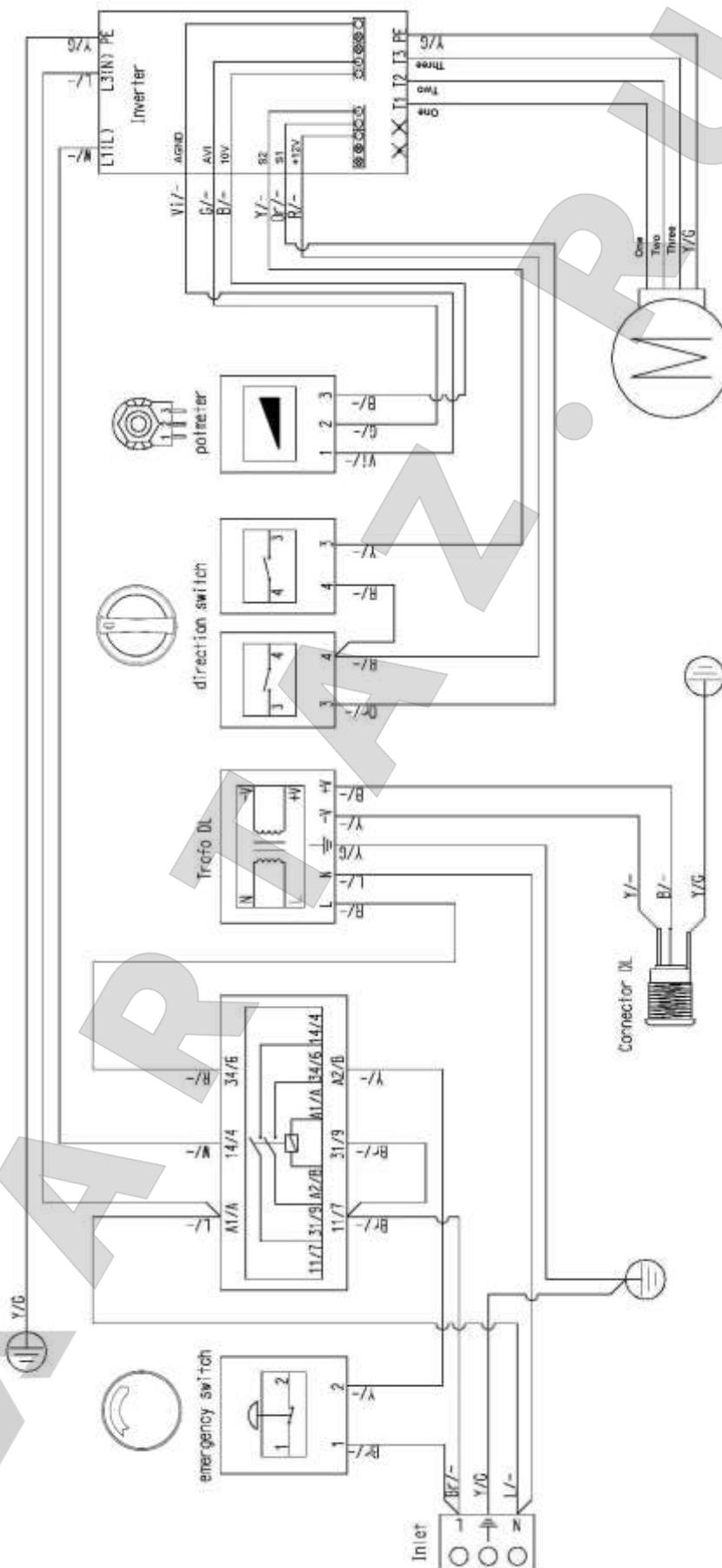


Fig. 72



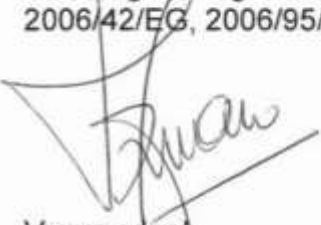
### 13. Technical Specifications

| <b>DL2002 Lathe</b>  |  |
|--|--|
| Maximum brake disc thickness   | 41 mm (1.61 inch)  |
| Adjustment knob cutting depth accuracy   | 0.05 mm (0.002 inch)   |
| Feed rate  | 6, 12, 50, 475 mm/min.<br>(0.24, 0.47, 1.97, 18.7 inch/min.) |
| Electrical specifications  | See information plate  |
| Net weight   | 7.7 kg (17 Lbs)  |
| <b>DU2010 Drive Unit</b>   |  |
| Working height min./max.   | 45 - 125 cm (18 - 49 inch)                                   |
| Drive speed  | 80 - 160 rpm   |
| Net weight   | 52 kg (115 Lbs)  |
| Electrical specifications  | See information plate  |
| Ambient temperature range  | -5°C to 40°C (23°F to 104°F)                                 |
| Year of construction   | See information plate  |
| <b>Turning accuracy</b>  |  |
| Brake disc runout  | 0.002 mm (79 microinch)                                      |
| Brake disc thickness variation   | 0.002 - 0.005 mm<br>(79 - 197 microinch)                     |
| Brake disc surface roughness   | Ra 1.0 - 2.0 $\mu$ m<br>(39 - 79 microinch)                  |
| Noise level, excluding a space correction factor of 4 dB(A)<br>(NEN-ISO 11204 en ISO 3746) | 74 dB(A)   |

Tab.2.

## 14. CE-declaration of conformity

We M.A.D. Holding B.V.,  
Wiltonstraat 53, NL-3905 KW, Veenendaal, the Netherlands,  
declare that the On the car lathe DL2002 with Drive Unit DU2010, conforms to CE  
following the regulations of the directives;  
2006/42/EG, 2006/95/EG, 2004/108/EG

  
Veenendaal  
February 20, 2015  
General Manager  
J.M. van der Zwan

## 15. Disposal instructions

As a responsible retailer we care about the environment. As such we urge you to follow the correct disposal procedure for your product, batteries and packaging materials.

This will help conserve natural resources and ensure that it is recycled in a manner that protects health and the environment.

You must dispose of this product and its packaging according to local laws and regulations. Because this product contains electronic components and sometimes batteries, the product and its accessories must be disposed of separately from household waste when the product reaches its end of life.

Contact your local authority to learn about disposal and recycling. The product and if applicable, its batteries should be taken to your local collection point for recycling. Some collection points accept products free of charge.

We apologize for any inconvenience caused by minor inconsistencies in these instructions, which may occur as a result of product improvement and development.





## 16. Guarantee conditions for MAD equipment

1. M.A.D. Holding BV of Veenendaal, Netherlands, referred to hereafter as MAD, gives a 12-month manufacturer's guarantee on their equipment, components and accessories for the machining of brake discs: against manufacture, assembly or design defects.
2. Damage resulting from inappropriate use or damage in transit is excluded from the manufacturer's guarantee.
3. This guarantee applies only to the supply of brand-new equipment and components.
4. The date on which this guarantee comes into effect is determined by the date of its delivery to the end-user; the date shown on the MAD dealer's invoice is definitive.
5. All parts that are subject to wear-and-tear are excluded from the guarantee, as are components/products that are explicitly supplied under different guarantee conditions.
6. Should the terms of the MAD guarantee be at variance with legally-prescribed conditions, such legal conditions shall prevail at all times. MAD conditions that fall outside the scope of the law shall persist in force.
7. The MAD dealer's own terms of sale and supply may restrict MAD's guarantee conditions, but cannot in any circumstances expand the scope of the manufacturer's guarantee.
8. Within the guarantee period, MAD will take care of the repair or replacement of goods supplied. This should be understood as meaning the repair and/or replacement of defective parts, in which case only the cost of materials and assembly shall be for MAD's account.
9. Consequential loss or damage does not qualify for compensation under guarantee. Any additional costs resulting from the use of the supplied parts or machine during their guarantee period are similarly excluded from compensation.
10. MAD is entitled to replace parts or machines under guarantee with other parts or components of at least equal value if the cost of repairing would be greater than the value of the parts under guarantee.
11. Should MAD decide not to repair or replace parts under guarantee, they will offer compensation, the amount of which shall not exceed the purchase price of the merchandise supplied.
12. MAD becomes the owner of parts replaced under guarantee upon providing a guarantee by repairing, replacing or refunding those parts.
13. When performing repairs during the guarantee period, a 3-month guarantee shall apply to the repairs, and a 12-month guarantee on components, with the exception of parts that are subject to wear-and tear.
14. In order to obtain a guarantee, the applicant must provide the parts in question to the MAD dealer, supplying the purchase invoice, or at least its exact reference.
15. Any shipping costs after warranty service shall be for MAD's account.





ARTAZ.RU

MAD Holding B.V.  
P.O. Box 760  
3900 AT Veenendaal  
The Netherlands  
T (+31)318 586 100  
F (+31)318 541 213  
E [info@mad-tooling.com](mailto:info@mad-tooling.com)  
I <http://www.mad-tooling.com>

