

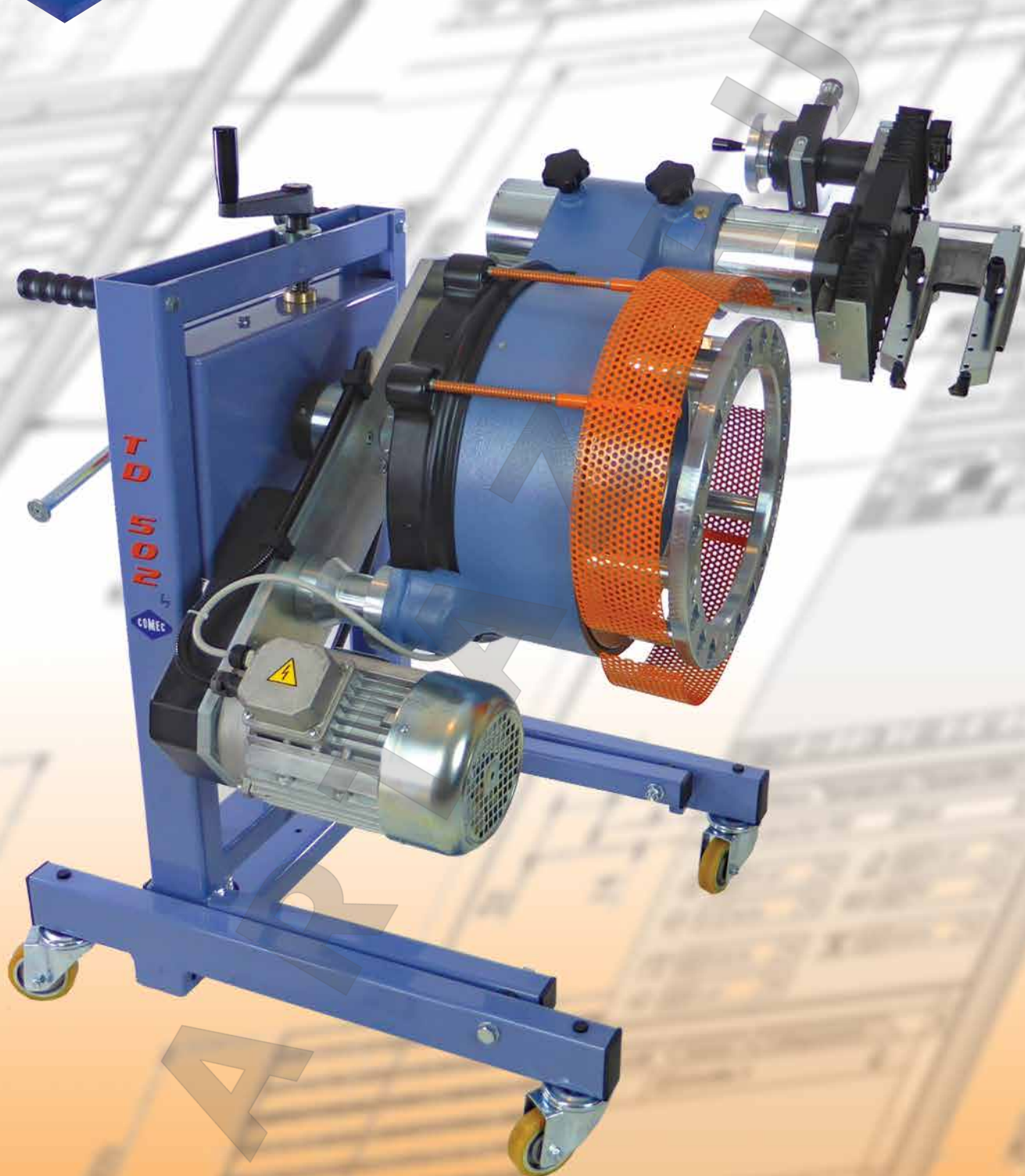

**TD502**



**TORNIO PER DISCHI FRENO MONTATI SUI VEICOLI PESANTI**  
**ON-THE-TRUCK BRAKE DISC LATHE FOR HEAVY DUTY VEHICLES**  
**MACHINE A TOURNER LES DISQUES DE FREINS POIDS LOURDS**  
**TORNO RECTIFICADOR DE DISCOS MONTADOS EN VEHICULOS PESADOS**





- Innesco avanzamento automatico e regolazione velocità avanzamento utensili
- *Engaging clutch for automatic feed and adjustable feed speed*
- Insertion avancement automatique et réglage vitesse des outils
- *Dispositivo de activación del avance automático y de regulación de la velocidad de avance de las herramientas*

- Utensili regolabili in maniera indipendente e fincorsa elettrico
- *Twin cutter easy and quick to set up and electrical stroke-end switch*
- Réglage outils de façon indépendante et fin de course électrique
- *Herramientas regulables de forma independiente y final de carrera electrónico*

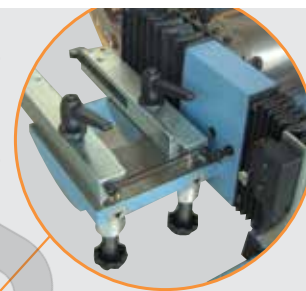

- Meccanismo di avanzamento intermittente degli utensili
- *Intermittent tool feed system*
- *Système avancement séquentiel outils*
- *Sistema de avance intermitente de las herramientas*

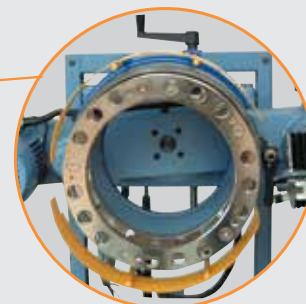
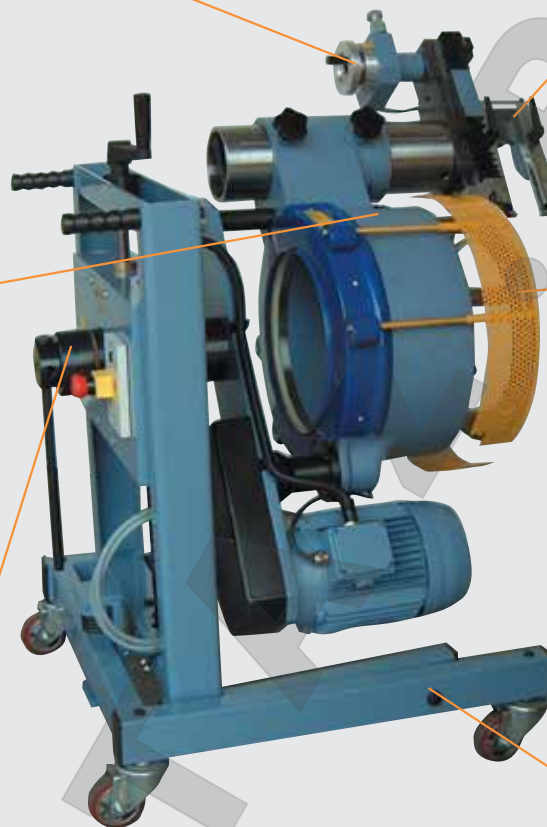

- Corpo macchina vuoto internamente per contenere il mozzo riduttore
- *Body machine with a obstacle free central part to contain the reduction-hub*
- *Corps machine vide pour contenir le moyeu reducteur*
- *Cuerpo de la maquina hueco en su interior para contener la maza reductora*



- Leva di bloccaggio per consentire la rotazione per il posizionamento
- *Locking lever to allow rotation and positioning*
- Levier de blocage pour permettre la rotation d'accouplement
- *Palanca de bloqueo para permitir la rotación en la operación de posicionamiento*

- Carrello basculante ed autoallineante per un'applicazione veloce e precisa
- *Pivoted and auto-aligning trolley for allow fast and accurate positioning*
- Chariot basculant et autoalignent pour un accouplement rapide et précise
- *Carro basculante y con auto centrado para un posicionamiento veloz y preciso*

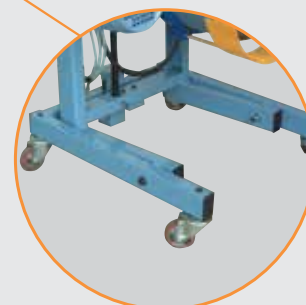

Dati tecnici	Specifications	Donées techniques	Datos técnicos
Min - Max diametro tornibile	<i>Min - Max working diameter</i>	Min - Max diametre tournage	<i>Min - máx diametro que se puede tornear</i> 100 ÷ 500 mm
Spessore massimo disco	<i>Max disc thickness</i>	Epaisseur maxi du disc	<i>Espesor máximo del disco</i> 70 mm
Max. lunghezza lavorabile	<i>Max warking width</i>	Maxi hauteur de travail	<i>Largo máximo que se puede tornear</i> 150 mm
Velocità di rotazione	<i>Rotation speed</i>	Vitesse de rotation	<i>Velocidad de rotación</i> 70 rpm
Avanzamento variabile intermitt.	<i>Variable intermittent feed</i>	Avance intermittent variable	<i>Avance variable intermitente</i> 0 ÷ 0,3 mm/rev
Potenza motore	<i>Motor power</i>	Puissance motor	<i>Potencia del Motor</i> 2 Hp (1,5 Kw)
Dimensioni (LxLxH)	<i>Dimensions (LxWxH)</i>	Dimensions (LxLxH)	<i>Medidas (LxAxA)</i> 850x650x1050 mm



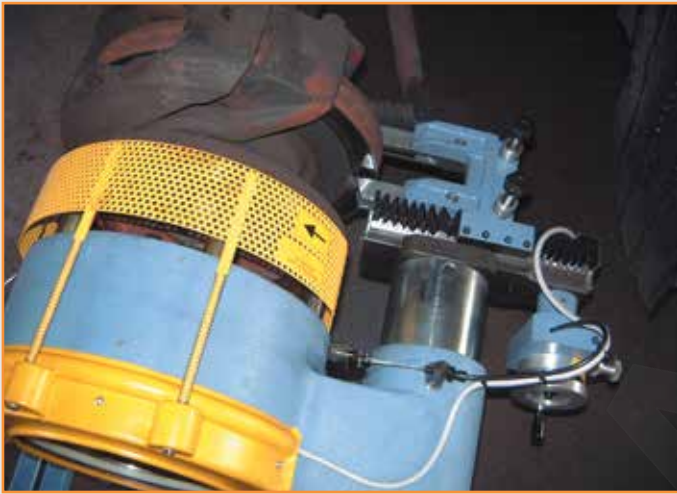

La TD 502 rivoluziona il concetto di tornitura dei dischi freno di veicoli industriali e autobus: non è più necessario smontare il disco per lavorarlo al tornio da banco ma è sufficiente applicare la macchina direttamente al mozzo.

Questa idea ha guidato la realizzazione di una macchina che riduce al minimo i tempi per questa operazione. Infatti è montata su un carrello auto-allineante (basculante e regolabile in altezza) che garantisce sempre il perfetto accoppiamento tra macchina e mozzo (quindi senza bisogno di ulteriori operazioni di allineamento o centratura con comparatore).

La forma costruttiva del corpo macchina, in ghisa monolitica e vuota centralmente, è l'ideale per gli assali con riduttore perché esso viene inglobato all'interno della macchina stessa riducendo la distanza tra questa ed il disco con indubbi vantaggi sulla precisione di lavoro. Inoltre l'avanzamento intermittente a regolazione variabile garantisce sempre una finitura ottimale delle superfici.

La TD 502 est une machine formidable qui révolutionne de façon complète le concept de reconditionnement des disques freins des poids lourds: il n'est pas plus nécessaire démonter les disques et les usiner sur le tour stationnaire, mais on fait l'opération directement sur l'essieu.

Dans cette idée on a projeté une machine que réduit au minimum le temps de rectification et donne, au même temps, une garantie de précision. La machine est placée sur un chariot basculant et réglable en hauteur qui permet de s'accoupler aux essieux des véhicules, de façon rapide et précise, même sans besoin du comparateur.

La forme constructive de la machine en fonte monolithique est vide dans son corps central, pour permettre la pénétration du moyeu réducteur au fin avoir un accouplement le plus proche possible aux disques à rectifier.

Ca c'est une chose très importante pour la précision du travail.

*The TD 502 completely changes the concept of truck and buses disc reconditioning.*

*No more time lost dismantling the disc for bench turning but an on-board application of the disc lathe.*

*This revolutionary idea has developed a machine that minimize the set-up time thanks to very simple operations.*

*It's mounted on a self-aligning trolley (swinging and height adjustable) that always guarantees the perfect matching between machine and hub (with no need for alignment or centering operations by means dials).*

*The body machine construction made of cast iron has a convenient obstacle free central part which doesn't interfere with the truck reducer (especially on rear axles), allowing a machine positioning very close to the disc for a much more precise reconditioning job.*

*Moreover the intermitted and adjustable feed grants an exceptional finishing on any surface.*

*El TD 502 revoluciona el concepto de torneado de los discos de frenos de los vehículos comerciales (camiones y buses): no es más necesario desmontar el disco para trabajarlo al torno de banco, siendo suficiente aplicar la máquina directamente en la maza.*

*Esta idea ha llevado a la realización de una máquina que disminuye al mínimo los tiempos de trabajo.*

*Se compone por un carro con funciones de auto-alineación (basculante y regulable en altura) que garantiza un perfecto acople entre la máquina y la maza (asi dispensando ulteriores operaciones de alineación o centrado con comparador). El sistema de construcción del cuerpo de la máquina, en hierro fundido monolítico y hueco en su centro, hace que sea ideal para los ejes con reductor, ya que el mismo es insertado en el interior del cuerpo, así reduciendo la distancia entre este y el disco, con importantes ventajas para la precisión del trabajo.*



- Carrello basculante ed autoallineante
- Utensile sagomato ad inserto dx UT5008
- Utensile sagomato ad inserto sx UT5009
- Anello adattatore AA0251
- Chiavi di servizio
- Libretto istruzioni

- Pivoted and self-aligning trolley for positioning
- Right hand L shaped toolholder UT5008
- Left hand L shaped toolholder UT5009
- Adapter ring AA0251
- Wrench set
- Instruction manual

- Chariot à bascule et auto-aligneant pour application
- Outil droit avec plaquette UT5008
- Outil gauche avec plaquette UT5009
- Anneau adaptateur AA0251
- Cles de service
- Manuel d'emploi

- Carro basculante y con auto alineación
- Herramienta derecha de corte UT 5008
- Herramienta izquierda de corte UT 5009
- Anillo de centrado AA0251
- Llaves de servicio
- Manual de instrucciones

Anelli adattatori • Adapter rings • Anneaux adaptateur • Anillos de centrado



AA0251

- 10 fori Ø: interasse 335 mm/centraggio 281 mm  
10 huecoi Ø: entre eje 335 mm/centrado 281 mm
- DAF: MB 220/230, F95.700
  - IVECO: Stralis, Eurotech, Eurostar, Cursor, Bus 370S/470
  - MAN: F2000, M2000, F90
  - MERCEDES: Actros, Bus D.335/D.480, Kassbohrer S215/216, Sica 970H, Setra S209H
  - RENAULT: Magnum, Premium
  - SCANIA: P 94D, L 124-144, R 124-144
  - VOLVO: FS 7.16/7.18/7.19, FM 7/10/12, FH 10/12/16, Bus B 10L/12L
  - RIMORCHI (Trailer): BPW, R.O.R., SAF

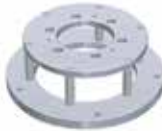

AA0056

- 6 fori Ø: interasse 170 mm/centraggio 130 mm  
6 huecoi Ø: entre eje 170 mm/centrado 130 mm
- IVECO: Daily Tutti i modelli (escluso 59.12), New Daily C9/11/13
  - NISSAN: L35, L50



AA0061

- 8 fori Ø: interasse 275 mm/centraggio 221 mm  
8 huecoi Ø: entre eje 275 mm/centrado 221 mm
- DAF: F55.210, F95.700
  - IVECO: Gamma Zeta 95.14-109.14, Turbo Zeta, Eurocargo 80-120-150-260-280-320-95 4x4
  - MAN: M2000/264, 13224
  - MERCEDES: Atego 13.23-15.23-15.27
  - RENAULT: Midliner M160-180-200-210-230-250
  - VOLVO: FL4.10, FL6.08-10-11

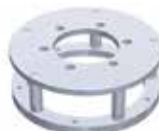

AA0265

- 6 fori Ø: interasse 205 mm/centraggio 161 mm  
6 huecoi Ø: entre eje 205 mm/centrado 161 mm
- DAF: F45.130-150-160-180
  - IVECO: Eurocargo 65-75, Daily 59.12, Daily C65-15, Bus 315S, Gamma Zeta 65.12-79.14
  - MERCEDES: Sprinter 408-410-412-413-416, Vario 512-612-614-714 ATEGO 815, Autobus 0609
  - NISSAN: L70, M90
  - RENAULT: S100-130-150-160-170, Midliner S120-135-150-180

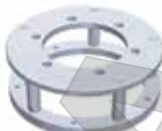

AA0275

- 6 fori Ø: interasse 245 mm/centraggio 202 mm  
6 huecoi Ø: entre eje 245 mm/centrado 202 mm
- MAN: L2000-6.103-8.153-9.153-10.153-10.223-11.223-13.224
  - MERCEDES: Atego 815-817-823-917-10.17-12.23 Vario 814D
  - RENAULT: Midlum 180



AA0077

- 5 fori Ø: interasse 203 mm/centraggio 164 mm  
5 huecoi Ø: entre eje 203 mm/centrado 164 mm
- 6 fori Ø: interasse 222 mm  
6 huecoi Ø: entre eje 202 mm
- ISUZU



TD5026

- Comparatore per allineamento
- Dial gauge for alignment
- Comparateur pour alignement
- Comparador para alineación

TD5027

- Soft-Starter con inverter
- Soft-Starter with inverter
- Soft-Starter avec inverter
- Soft-Starter con inverter

MNF502

- Versione Monofase dotata di inverter e variazione di giri
- Single phase version with inverter and adjustable rotation speed
- Version monophasique avec inverter et variation de vitesse
- Version monofasica con inverter y variador de revoluciones

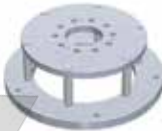

AA0078

- 5 fori Ø: interasse 130 mm/centraggio 85 mm  
Ø: interasse 118 mm (centraggio con dadi conici)
- IVECO: New Daily 29L9/11-35S9/11/13, Ducato 1.9-2.0-2.5-2.8-Maxi
  - MERCEDES: 207D-208D-209D-210D-307D-308D 309D-310D, MB100D, Sprinter 208D-308D-312D-214-314
  - RENAULT: Master



UT5008 / UT5009

- Utensile ad inserto sagomato destro (UT5008) e sinistro (UT5009)
- Right (UT5008) and left (UT5009) hand L shaped insert tool holder
- Outil droite (UT5008) et gauche (UT5009) avec plaquette
- Herramienta con inserto derecho (UT5008) e izquierdo (UT5009)



UT0012

- Inserto per UT0016-UT5008-UT5009 (10 pz.)
- Insert for UT0016-UT5008-UT5009 (10 pcs.)
- Plaquette pour UT0016-UT5008-UT5009 (10 pcs.)
- Inserto para UT 0016, UT 5008, UT 5009 (10 unidades)

