

DK20

Capacity 2.000 kg

DK20Q

Capacity 2.000 kg

DK13HLQ

Capacity 1.300 kg

DK20HLQ

Capacity 2.000 kg



(DK) (N) (GB) (D)
(F) (S) (SF) (NL) (E)

AC Hydraulic A/S

Fanøvej 6
DK-8800 Viborg - Danmark
Tel.: +45 8662 2166
Fax: +45 8662 2988
E-mail: ac@ac-hydraulic.dk
www.ac-hydraulic.com

0825001-070321-AC

**(GB) DK20, DK20Q, DK13HLQ
DK20HLQ****WARNING -
safe usage instructions**

1. Study, understand and follow all instructions before operating this jack.
2. Do not exceed rated capacity.
3. Use only on hard level surface.
4. It is recommended to brake and chock the vehicle.
5. Do not move or transport the vehicle while on the jack.
6. Lifting device only. Immediately after lifting, support the vehicle with support stands.
7. Lift only on areas of the vehicle as specified by the vehicle manufacturer, and only centrally on the lifting saddle.
8. No person shall remain in, on, or get bodily under a load that is being jacked or is supported only by a jack.
9. Only original accessories and spare parts shall be used.
10. No alterations shall be made to this jack.
11. Failure to follow these warnings may result in personal injury and/or property damage.

Assembly

Mount plastic handle on tube lever with inner projection to fit into slot. Push tube lever into handle until screw and nut can be mounted (use a rubber hammer to adjust handle position).

Then place lever in tipping gear, and secure it with tipping gear screw fitting into slot in tube lever.

Use

Lifting: Activate lever tube up and down using full strokes.

Lowering: Pull lever tube up, then slowly turn counter clockwise.

Maintenance

Maintenance and repair must always be carried out by qualified personnel.

Daily: Inspect jack for damages.

Monthly: Lubricate all mechanical parts with a few drops of oil.

Oil refill: Pump with cylinder is a closed system and refilling of oil is normally not necessary. In order to refill oil it is necessary to demount the hydraulic unit:

1. Untasten screw (16) through hole in base frame.
2. Release and lower the jack completely.
3. Keep lever vertically and block piston rod (31) in the inmost position by means of a screw or nail through hole in release bracket (39). Mind the inner spring!
4. Remove lever tube and tipping gear as well as the two screws (7) on top of lifting frame.
5. Now the hydraulic unit is loose and can be removed up front from the lifting frame.
6. Assembly takes place in reverse order. Pump the jack half-way up in order to ease mounting of the last screw (16).

Correct oil level is up to lower edge of filling hole (27) with the cylinder vertical and the piston rod pushed completely in. Too much oil causes poor pumping.

Quantity of oil: DK20, DK20Q and DK13HLQ: **0,3 l.**
DK20HLQ: **0,5 l.**

Any good hydraulic oil of viscosity ISO VG 15 can be used.

Never use brake fluid!

Safety Inspection

According to national legislation - minimum once a year though - the jack must be inspected by a professional: damages, wear and tear, adjustment of the safety valve, hydraulic unit for leakages.

Possible faults and how to overcome them

1. The load is dropping occasionally: Verify the play between release bracket (39) and lever tube. Adjust the two nuts (11) until the play is 1-2 mm, irrespective of the lever tube position (vertical or horizontal).
2. The jack does not lift to maximum position: refill with oil.
3. The load is dropping: leaking pump valves or worn seals. Inspect the valve seats + balls under plug (46) and change seals in lifting cylinder.
4. The hydraulic unit is leaking: exchange worn seals with repair kit 0906000.

Spare parts

Replace worn or broken parts with genuine jack manufacturer supplied parts only. All major parts may not be provided after discontinuation of a model.

Destruction

Oil must be drained off and legally disposed of.





DK20

DK20Q

DK13HLQ

DK20HLQ

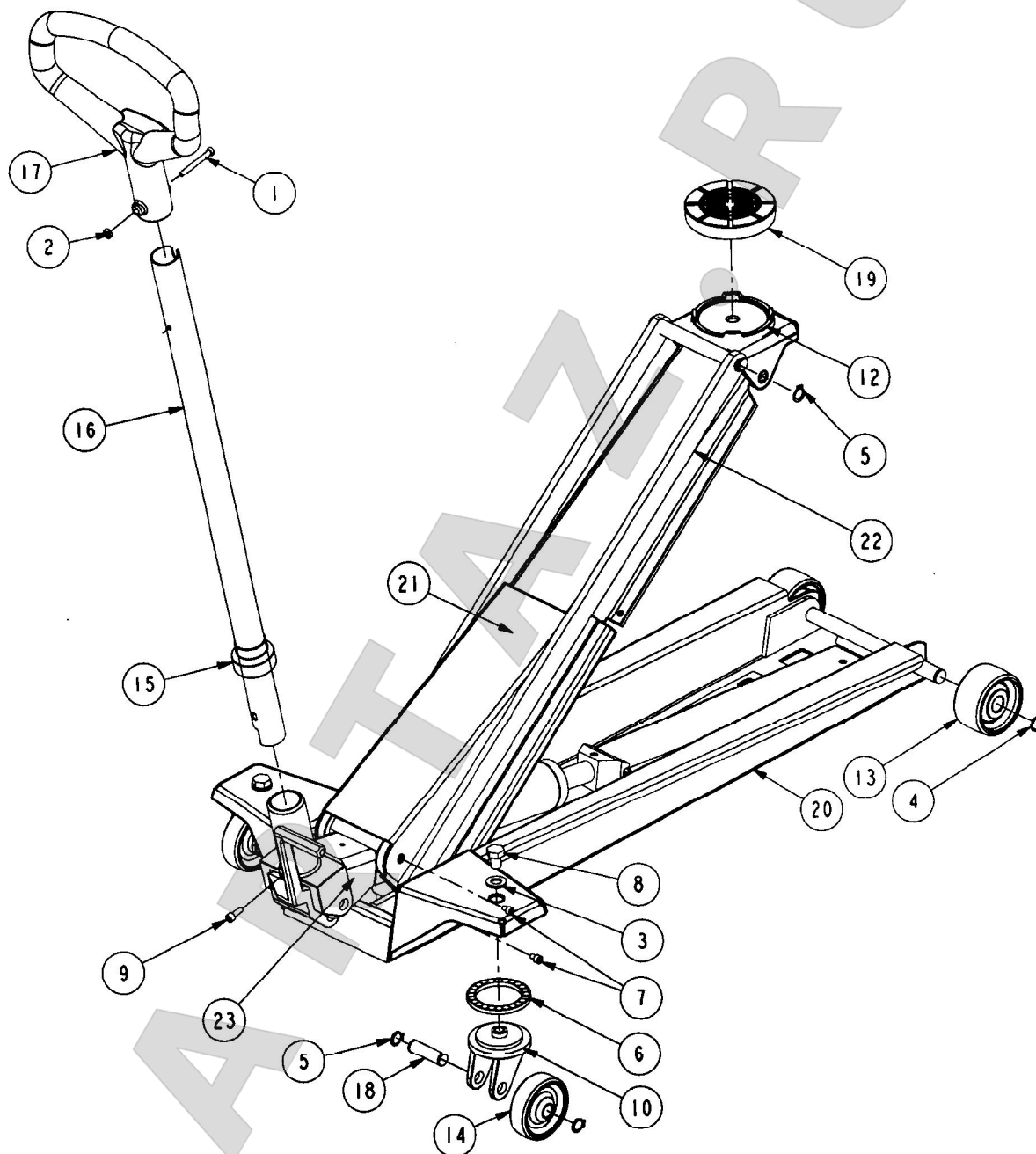



	DK20	DK20Q	DK13HLQ	DK20HLQ	(DK)	(GB)	(D)	
Pos.	Art. No.	Art. No.	Art. No.	Art. No.	Pcs	Benævnelse	Description	Bezeichnung
	36 000 00	36 015 00	36 020 00	36 050 00	1	Donkraft, kompl.	Jack, compl.	Rangierheber, kompl.
1	02 028 00	02 028 00	02 028 00	02 028 00	1	Skruer	Screw	Schraube
2	02 072 00	02 072 00	02 072 00	02 072 00	1	Møtrik	Nut	Mutter
3	02 121 00	02 121 00	02 121 00	02 121 00	2	Skive	Washer	Scheibe
4	02 204 00	02 204 00	02 204 00	02 204 00	2	Låsering	Locking ring	Schließring
5	02 224 00	02 224 00	02 224 00	02 224 00	8	Låsering	Locking ring	Schließring
6	02 261 00	02 261 00	02 261 00	02 261 00	2	Trykleje	Thrust bearing	Drucklager
7	02 307 00	02 307 00	02 307 00	02 307 00	4	Skruer	Screw	Schraube
8	02 328 00	02 328 00	02 328 00	02 328 00	2	Skruer	Screw	Schraube
9	02 346 00	02 346 00	02 346 00	02 346 00	1	Skruer	Screw	Schraube
10	36 003 00	36 003 00	36 003 00	36 003 00	2	Hjulgaffel	Wheel fork	Radgabel
12	36 006 00	36 006 00	36 006 00	36 006 00	1	Sadel	Saddle	Sattel
13	36 007 00	36 007 00	36 007 00	36 007 00	2	Hjul - fast	Wheel fixed	Rad - fest
14	36 008 00	36 008 00	36 008 00	36 008 00	2	Hjul - svingbar	Wheel, pivoting	Rad - schwenkbar
15	36 009 00	36 009 00	36 009 00	36 009 00	1	Plastkappe	Plast covering	Plastkappe
16	36 010 00	36 010 00	36 010 00	36 010 00	1	Håndtagsrør	Lever tube	Handhebelrohr
17	36 011 00	36 011 00	36 011 00	36 011 00	1	Bøjlegreb	Handle	Griff
18	36 012 00	36 012 00	36 012 00	36 012 00	2	Aksel	Axle	Achse
19	36 014 00	36 014 00	36 014 00	36 014 00	1	Gummisadel (tilbehør)	Rubber saddle (option)	Gummisattel (Zubehör)
20	36 001 00	36 001 00	36 021 00	36 051 00	1	Køreramme	Base frame	Fahrrahmen
21	36 002 00	36 002 00	36 022 00	36 052 00	1	Løfteramme	Lifting frame	Heberahmen
22	36 005 00	36 005 00	36 023 00	36 023 00	2	Parallelstang	Steering rod	Parallelstange
23	91 050 00	91 070 00	91 070 00	91 075 00	1	Pumpe, komplet	Pump, complete	Pumpe, komplett





91 050 00
91 070 00
91 070 00
91 075 00

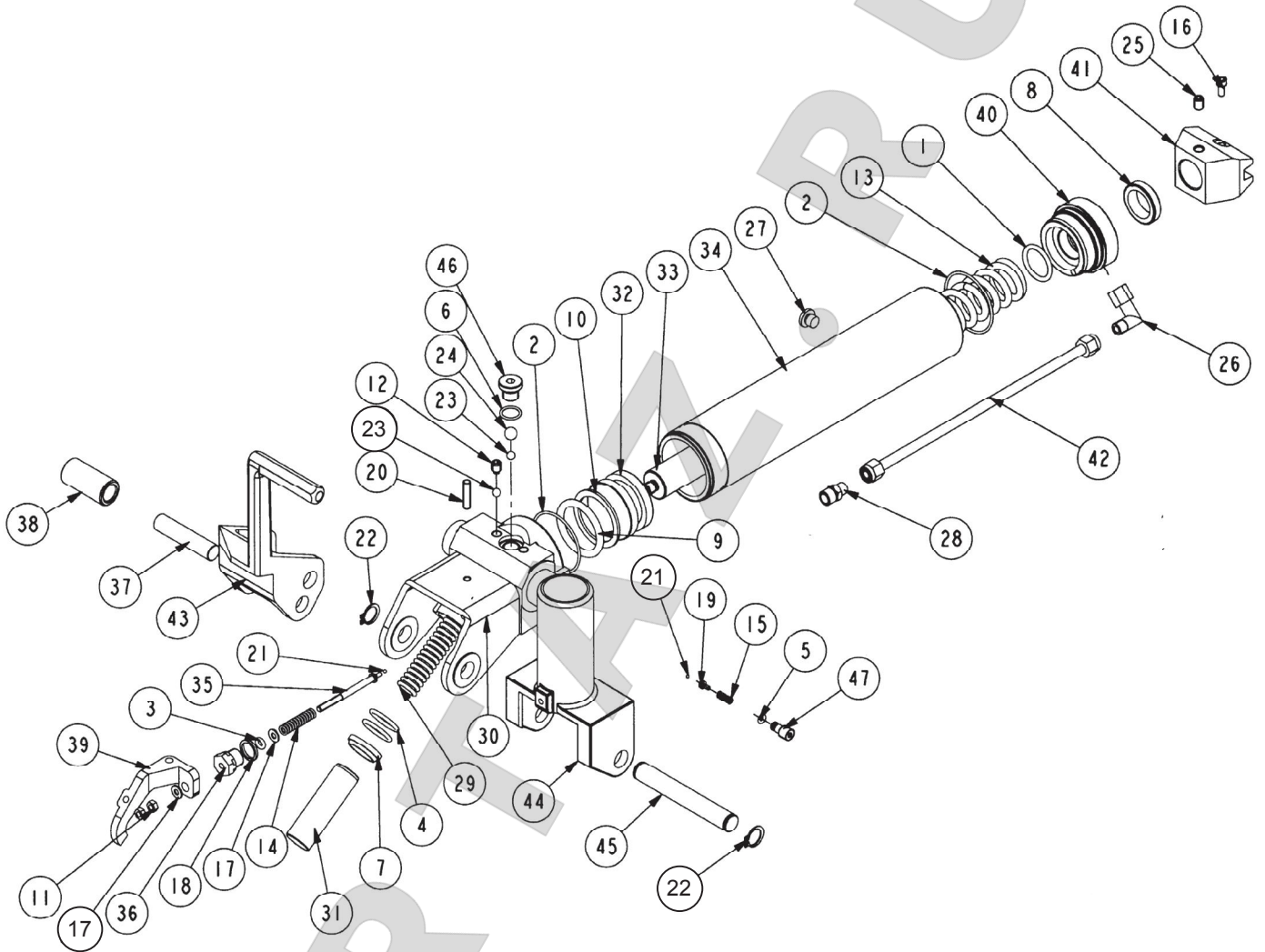



	DK20	DK20Q	DK13HLQ	DK20HLQ	(DK)	(GB)	(D)	
Pos.	Art. No.	Art. No.	Art. No.	Art. No.	Pcs.	Beskrivelse	Description	Bezeichnung
	91 050 00	91 070 00	91 070 00	91 075 00	1	Pumpe, komplet	Pump, complete	Pumpe komplett
*1	01 015 00	01 015 00	01 015 00	01 049 00	1	O-ring	O-ring	O-Ring
*2	01 038 00	01 038 00	01 038 00	01 038 00	2	O-ring	O-ring	O-Ring
*3	01 039 00	01 039 00	01 039 00	01 039 00	1	O-ring	O-ring	O-Ring
*4	01 051 00	01 051 00	01 051 00	01 051 00	2	O-ring	O-ring	O-Ring
*5	01 089 00	01 089 00	01 089 00	01 089 00	1	O-ring	O-ring	O-Ring
*6	01 239 00	01 239 00	01 239 00	01 239 00	1	O-ring	O-ring	O-Ring
*7	01 254 00	01 254 00	01 254 00	01 254 00	1	Afstryger	Scraper ring	Abstreifer
*8	01 269 00	01 269 00	01 269 00	01 261 00	1	Afstryger	Scraper ring	Abstreifer
*9	01 306 00	01 306 00	01 306 00	01 306 00	1	O-ring	O-ring	O-Ring
*10	01 308 00	01 308 00	01 308 00	01 308 00	1	Back-up ring	Back-up ring	Back-up ring
11	02 016 00	02 016 00	02 016 00	02 016 00	2	Møtrik	Nut	Mutter
12	02 026 00	02 026 00	02 026 00	02 026 00	1	Udluftningsskrue	Air escape screw	Entlüftungsschraube
13	02 036 00	02 036 00	02 036 00	02 098 00	1	Fjeder	Spring	Feder
14	02 054 00	02 054 00	02 054 00	02 054 00	1	Fjeder	Spring	Feder
15	02 078 00	02 078 00	02 078 00	02 078 00	1	Fjeder	Spring	Feder
16	02 085 00	02 085 00	02 085 00	02 085 00	1	Skrue	Screw	Schraube
17	02 108 00	02 108 00	02 108 00	02 108 00	2	Skive	Washer	Scheibe
*18	02 132 00	02 132 00	02 132 00	02 132 00	1	CU-skive	Cu-washer	CU-Scheibe
19	02 155 00	02 155 00	02 155 00	02 155 00	1	Skrue	Screw	Schraube
20	02 156 00	02 156 00	02 156 00	02 156 00	1	Stopskrue	Stop screw	Anschlagschraube
*21	02 183 00	02 183 00	02 183 00	02 183 00	2	Kugle ø2,5	Ball ø2,5	Kugel ø2,5
22	02 224 00	02 224 00	02 224 00	02 224 00	2	Låsering	Locking ring	Schließring
*23	02 292 00	02 292 00	02 292 00	02 292 00	2	Kugle ø6,5	Ball ø6,5	Kugel ø6,5
*24	02 294 00	02 294 00	02 294 00	02 294 00	1	Kugle ø10	Ball ø10	Kugel ø10
25	02 313 00	02 313 00	02 313 00	02 313 00	1	Skrue	Pointed screw	Schraube
26	02 417 00	02 417 00	02 417 00	02 417 00	1	Forskruning	Gland	Verschraubung
27	02 448 00	02 448 00	02 448 00	02 448 00	1	Påfyldningsskrue	Filling plug	Füllschraube
28	02 498 00	02 498 00	02 498 00	02 498 00	1	Forskruning	Gland	Verschraubung
29	02 685 00	02 685 00	02 685 00	02 685 00	1	Fjeder	Spring	Feder
30	91 051 00	91 051 00	91 051 00	91 051 00	1	Pumpehus	Pump body	Pumpgehäuse
31	91 052 00	91 052 00	91 052 00	91 052 00	1	Pumpestempel	Pump piston	Pumpkolben
32	91 053 00	91 053 00	91 053 00	91 053 00	1	Stempel	Piston	Kolben
33	91 054 00	91 054 00	91 054 00	91 073 00	1	Stempelstok	Piston rod	Kolbenstange
34	91 055 00	91 055 00	91 055 00	91 072 00	1	Cylinderrør	Cylinder tube	Zylinderrohr
35	91 056 00	91 056 00	91 056 00	91 056 00	1	Udløserspindel	Release spindle	Auslöserspindel
36	91 057 00	91 057 00	91 057 00	91 057 00	1	Udløserstyr	Release guide	Auslöserführung
37	91 060 00	91 060 00	91 060 00	91 060 00	1	Rulleaksel	Rolling axe	Rollenachse
38	91 061 00	91 061 00	91 061 00	91 061 00	1	Rulle	Roll	Rollen
39	91 063 00	91 063 00	91 063 00	91 063 00	1	Udløserbøjle	Release bracket	Auslöserbügel
40	91 064 00	91 064 00	91 064 00	91 071 00	1	Cylindermøtrik	Cylinder nut	Zylindermutter
41	91 065 00	91 065 00	91 065 00	91 065 00	1	Adapter	Adaptor	Adaptor
42	91 066 00	91 066 00	91 066 00	91 076 00	1	Olieslange	Oil hose	Ölschlauch
43		91 067 00	91 067 00	91 067 00	1	Fodpedal	Pedal	Fußhebel
44	91 058 00	91 068 00	91 068 00	91 068 00	1	Nikketøj	Tipping gear	Kippvorrichtung,
45	91 062 00	91 069 00	91 069 00	91 069 00	1	Aksel	Axle f. tipping gear	Achse
46	91 077 00	91 077 00	91 077 00	91 077 00	1	Prop	Plug	Pfropfen
47	95 005 02	95 005 02	95 005 02	95 005 02	1	Justerskrue	Adjusting screw	Justierschraube
*	09 060 00	09 060 00	09 060 00	09 060 00		Pakningssæt	Repair kit	Dichtungssatz

DK: De med * mærkede dele leveres i komplet pakningssæt. Anvend altid originale reservedele. Angiv venligst altid model og reservedelsnummer. Alle hoveddele kan ikke forventes leveret efter produktionsophør af model.

GB: * indicate parts included in repair set. Please always state model and part number. Do always apply original spare parts.

All major parts may not be provided as spare parts after discontinuation of production of a model.

D: Die mit * markierten Teile sind im Dichtungssatz enthalten. Bitte immer Modell und Ersatzteilnummer auf Ihren Bestellungen angeben. Immer nur Originalteile verwenden. Lieferung von allen Hauptteilen als Ersatzteile kann nach Produktions-Einstellung eines Modelles nicht erwartet werden.



(DK) TILBEHØR
(GB) ACCESSORIES
(D) ZUBEHÖR

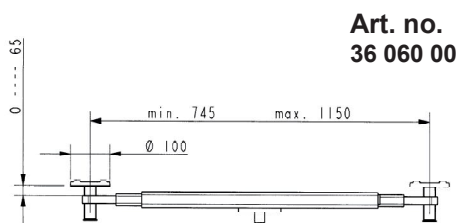

Art. no.
36 060 00

(DK) Benævnelse
T3 - Løftetravers
For moderne biler uden forbro.
(Tilladelig last 1000 kg)

(GB) Description
T3 - Cross Beam Adaptor
For modern vehicles without axle beam
(Permissible load 1000 kg)

(D) Bezeichnung
T3 - Achstraverse
Für moderne Autos die keine Fronttraverse haben
(Zulässig Belastung 1000 kg)

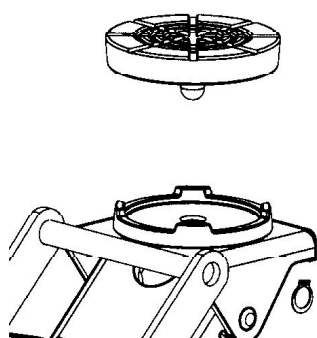

Art. no.
36 014 00

GS - Gummisadel
Beskytter undervogn. Passer også på 36 060 00 løftetravers
Tappen på gummisadel skal smøres med glidemiddel før montage.

GS - Rubber Saddle
For protection of car body Also for use on 36 060 00 cross beam adaptor.
Grease the tap of the rubber saddle prior to assembly.

GS - Gummisattelkissen
Zum Schonen des Fahrzeugbodens Passt auch zu 36 060 00 Achstraverse. Das Zapfen des Gummisattels vor Montage einschmieren.

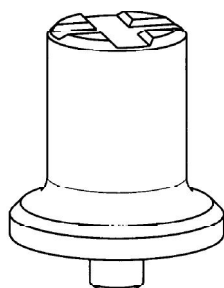

Art. no.
36 016 00

F-DK1
Forlænger 100 mm

F-DK1
Extension 100 mm

F-DK1
Verlängerung 100 mm

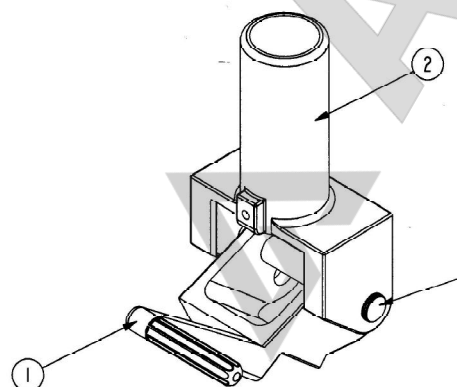

Art. no.
91 074 00

Nikketøj - sæt
Til ændring af DK20 til DK20Q

Tipping Gear Set
To change DK20 into DK20Q

Kippvorrichtung - satz
Um DK20 auf DK20Q zu ändern

Pos. 1
1 stk. 91 067 00
Q pedal

Pos. 1
1 pc. 91 067 00
Q pedal

Pos. 1
1 St. 91 067 00
Q Pedal

Pos. 2
1 stk. 91 068 00
Q nikketøj

Pos. 2
1 pc. 91 068 00
Q tipping gear

Pos. 2
1 St. 91 068 00
Q Kippvorrichtung

Pos. 3
1 stk. 91 069 00
Aksel

Pos. 3
1 pc. 91 069 00
Axle

Pos. 3
1 St. 91 069 00
Achse



EU Overensstemmelseserklæring
EC Declaration of Conformity for Machinery
EG Konformitätserklärung
Vaatumustenmukaisuuvakuutus

EC Declaration of Conformity for Machinery
Declaration CE de conformité
pour les composants
EU verklaring van overeenstemming
EU declaración de conformidad sobre maquinaria

Directive 98/37/EEC



- (DK)** Hydrauliske donkrafte,
(N) **DK20, DK20Q, DK13HLQ, DK20HLQ**
er i overensstemmelse med Maskindirektivets bestem-
melser (Direktiv 98/37/EEC og EN1494) med ændring,
og er i overensstemmelse med andre relevante natio-
nale bestemmelser.
- (GB)** Hydraulic Garage Jacks,
DK20, DK20Q, DK13HLQ, DK20HLQ
are in conformity with the provisions of the Machinery
Directive (Directive 98/37/EEC and EN1494) as amen-
ded andwith national implementing legislation.
- (D)** Hydraulische Rangierheber,
DK20, DK20Q, DK13HLQ, DK20HLQ
konform sind mit den einschlägigen Bestimmungen
der EG-Maschinenrichtlinie 98/37/EEC und EN1494
inklusive deren Änderungen, sowie mit dem ent-
sprechenden Rechtserlaß zur Umsetzung der
Richtlinie ins nationale Recht.
- (F)** Crics rouleurs hydraulique,
DK20, DK20Q, DK13HLQ, DK20HLQ
sont conformes aux dispositions de la Directive Machi-
ne 98/37/CEE et EN1494, et aux législations nationales
la transposant.
- (S)** Hydrauliska domkrafter
DK20, DK20Q, DK13HLQ, DK20HLQ
Överensstämmer med Maskindirektivets bestämmelser
(Direktiv 98/37/ECC och EN1494) med ändring ,och
är i överensstämmelse med andra relevanta nationella
bestämmelser
- (SF)** Hydraulisen hallinostin käyttöohjeet,
DK20, DK20Q, DK13HLQ, DK20HLQ
vastaa Konedirektiivin (direktiivi 98/37/EEC ja EN1494)
määräyksiä sekä kansallista voimaantulolainsäädäntöä.
- (NL)** Hydraulische rolkrik,
DK20, DK20Q, DK13HLQ, DK20HLQ
in overeenstemming zijn met de bepalingen van de
Richtlijn Machines (richtlijn 98/37/EEC en EN1494)
en met de essentiële veiligheidsen gezondheidseisen
(ARAB).
- (E)** Los gatos hidraulicos,
DK20, DK20Q, DK13HLQ, DK20HLQ
son conforme con las directrices sobre maquinaria
(Directiva 98/37/EEC y EN1494) incl.enmiendas,
y en conformidad con las directrices nacionales
relevantes.

Viborg 01.10.05

Claus A. Christensen
General Manager

Subject to changes and misprints.

